

W40000 STORAGE TANK SPECIFICATIONS

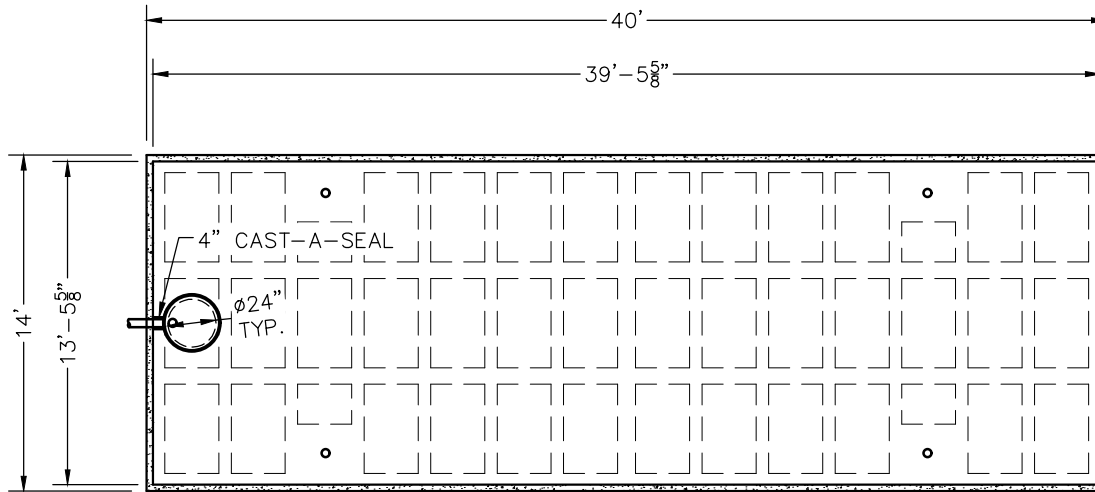

TOP VIEW

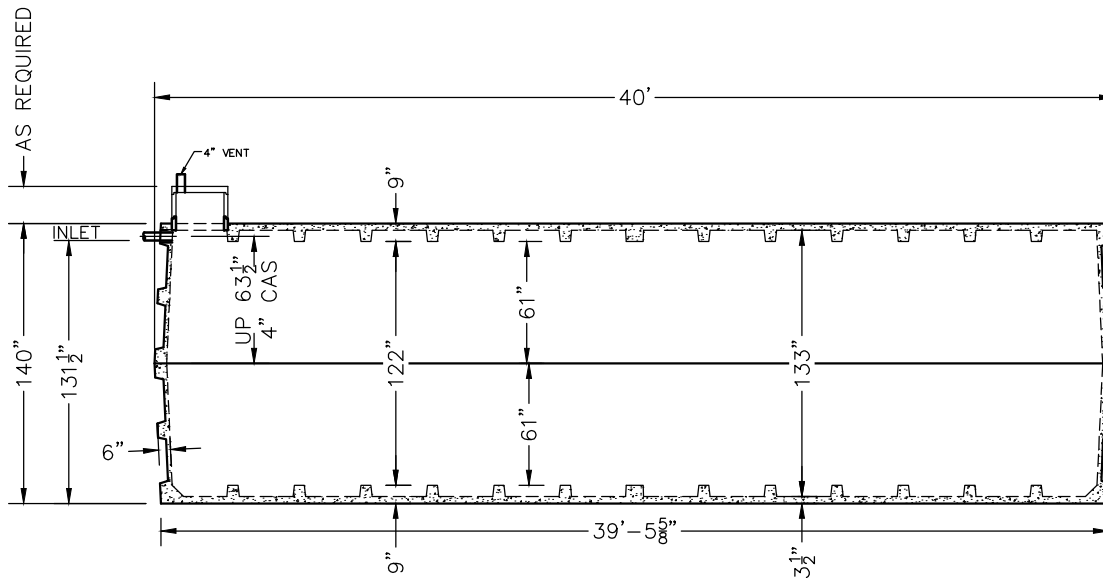

SIDE VIEW

DIMENSIONS:
 WALL: 6" RIBBED
 BOTTOM: 9" RIBBED
 COVER: 9" RIBBED
 MANHOLE: 24" I.D. PRECAST CONCRETE RISER
 HEIGHT: 140"
 LENGTH: 40'-0"
 WIDTH: 14'-0"
 BELOW INLET: 131 1/2"
 LIQUID LEVEL: 133"
 WEIGHT: 70,000 LBS. PER SECTION

INLET:
 4" CAST-A-SEAL BOOT
 OR EQUAL GASKET

LIQUID CAPACITY: 305.00 GAL/IN

LOADING DESIGN: 8'-0" UNSATURATED SOIL

TANK CAN BE USED AS:
 STORAGE TANK

TANK: MIX DESIGN #9 (SMALL FIBER)

CUSTOMIZED TANKS:
 FOR CUSTOM TANKS CONTACT
 WIESER CONCRETE

PRE-POUR:	DATE:
POST-POUR:	REV.
SCALE: 1/8" = 1'-0"	DRAWN BY: WCP
	DATE: 00/00/00
	FILE: w40000 storage

WIESER CONCRETE
 W3716 US HWY 10, MAIDEN ROCK, WI 54750
 800-325-8456

W40000 STORAGE
 SEPTIC MANUAL

REVIEWED BY _____
 REVIEW DATE _____

DRAWINGS SUBMITTED FOR APPROVAL

APPROVED BY: _____
 APPROVAL DATE: _____
 PRODUCTS NEEDED BY: _____

SHEET NO.
 1 OF 1

TANKS ARE MANUFACTURED TO MEET OR EXCEED ASTM C-1227 REQUIREMENTS