

W2400 BIO 1000 GPD HIGH STRENGTH FAST® 1.0 TANK SPECIFICATIONS

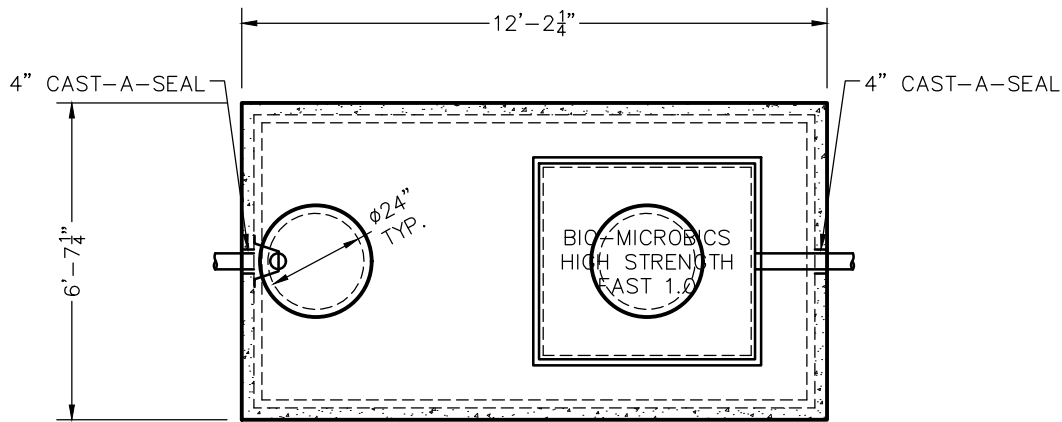

TOP VIEW

DIMENSIONS:

- WALL: 3"
- BOTTOM: 3"
- COVER: 5"
- MANHOLE: 24" I.D. PRECAST CONCRETE RISER
- HEIGHT: 76" O.D.
- LENGTH: 12'-2 1/4" O.D.
- WIDTH: 6'-7 1/4" O.D.
- BELOW INLET: 61" O.D.
- LIQUID LEVEL: 49"
- WEIGHT: BOTTOM 15,065 LBS.
COVER 5,030 LBS.

INLET AND OUTLET:

4" CAST-A-SEAL BOOT OR EQUAL GASKET

INLET AND OUTLET BAFFLES:

AS SHOWN

LIQUID CAPACITY: 42.64 GAL/IN

LOADING DESIGN: 8'-0" UNSATURATED SOIL

COVER: MIX DESIGN #8 (NO FIBER)

TANK: MIX DESIGN #9 (SMALL FIBER)

CUSTOMIZED TANKS:

FOR CUSTOM TANKS CONTACT WIESER CONCRETE

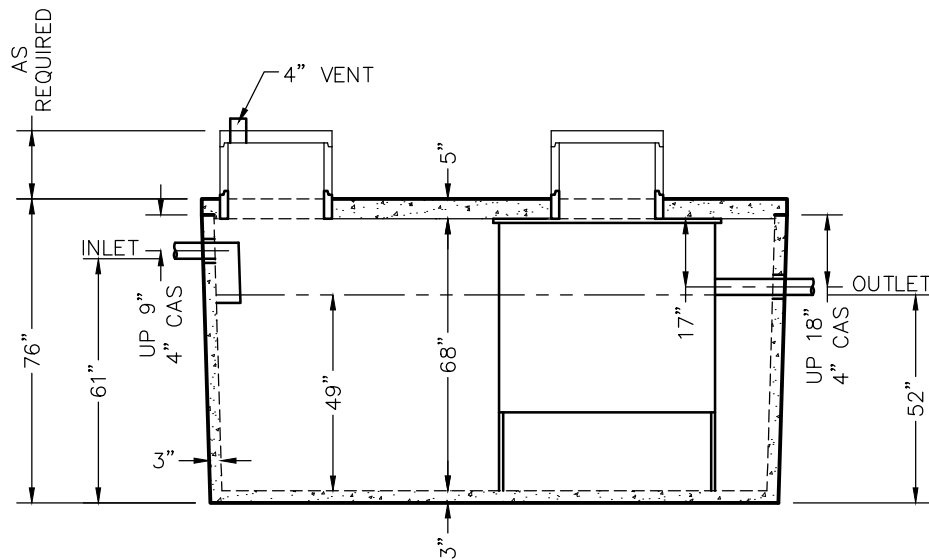

SIDE VIEW

PRE-POUR:	DATE:	REV.	SCALE: 1/4" = 1'-0"
POST-POUR:			DRAWN BY: WCP
			DATE: 00/00/00
			FILE: w2400 bio hs fast 1000

WIESER CONCRETE
W3716 US HWY 10, MAIDEN ROCK, WI 54750
800-325-8456

W2400 BIO HS FAST 1000
SEPTIC MANUAL

SHEET NO.
1 OF 1

REVIEWED BY _____
REVIEW DATE _____

**DRAWINGS SUBMITTED
FOR APPROVAL**

APPROVED BY: _____
APPROVAL DATE: _____
PRODUCTS NEEDED BY: _____