

W18000 GREASE INTERCEPTOR TANK SPECIFICATIONS

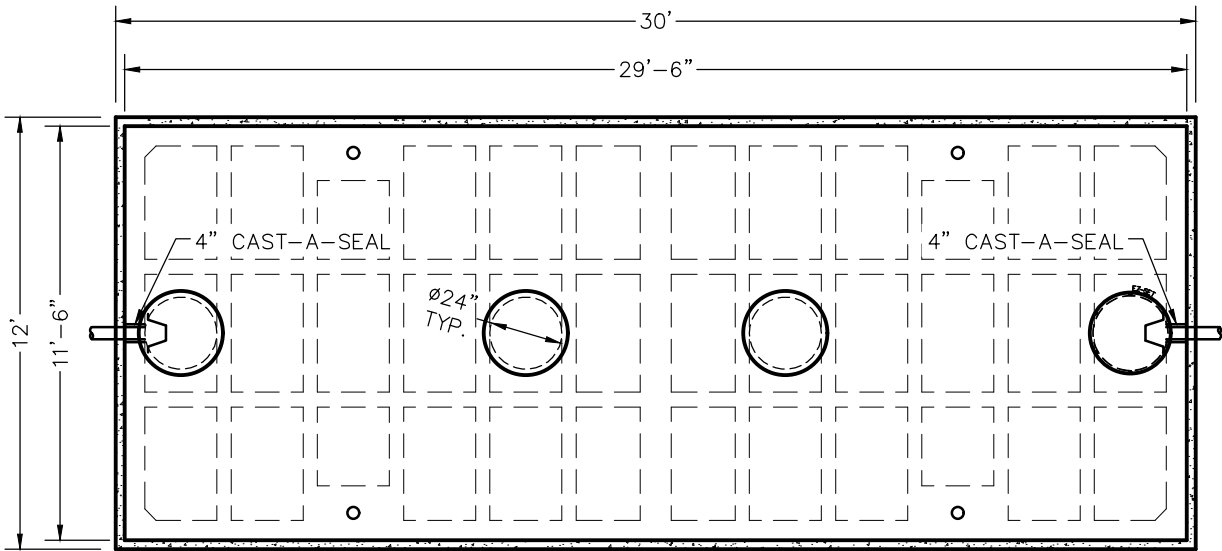

TOP VIEW

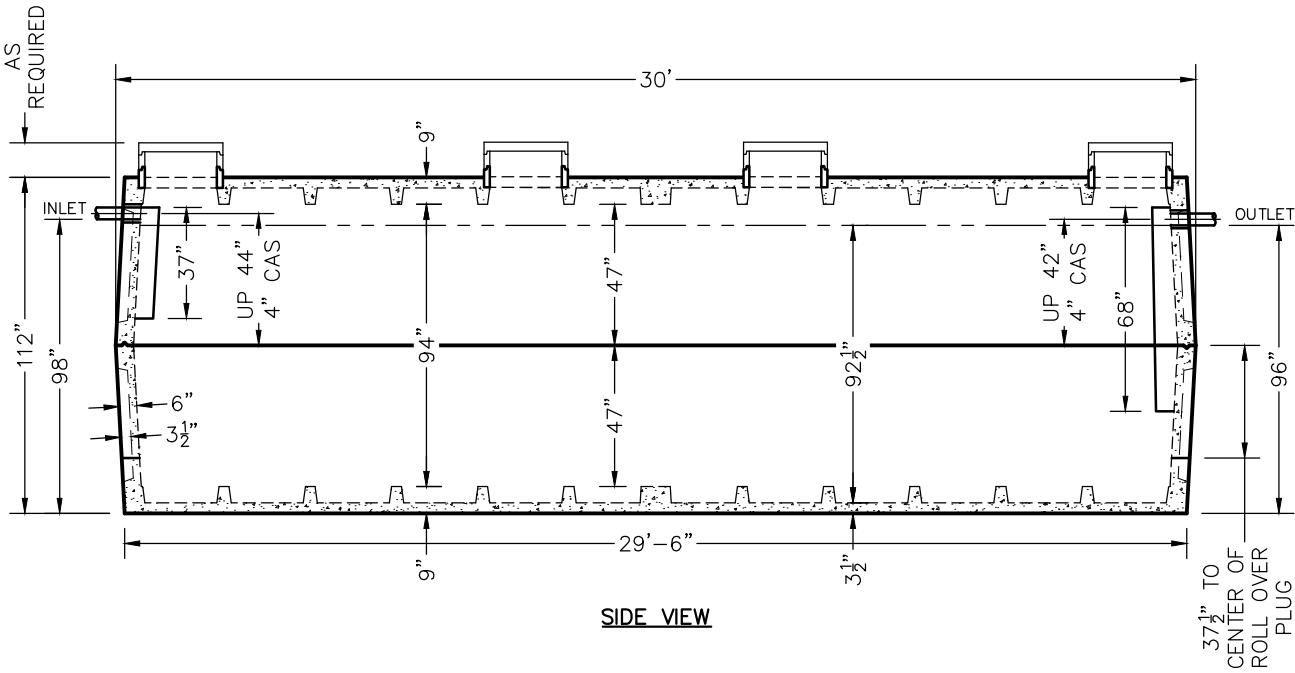

SIDE VIEW

DIMENSIONS:
 WALL: 6" RIBBED
 BOTTOM: 9" RIBBED
 COVER: 9" RIBBED
 MANHOLE: 24" I.D. PRECAST CONCRETE RISER
 HEIGHT: 112"
 LENGTH: 30'-0"
 WIDTH: 12'-0"
 BELOW INLET: 98"
 LIQUID LEVEL: 92 1/2"
 WEIGHT: 42,000 LBS. PER SECTION

INLET AND OUTLET:
 4" CAST-A-SEAL BOOT
 OR EQUAL GASKET

INLET AND OUTLET Baffle AND FILTER:
 AS SHOWN

LIQUID CAPACITY: 194.63 GAL/IN

LOADING DESIGN: 8'-0" UNSATURATED SOIL

TANK CAN BE USED AS:
 GREASE INTERCEPTOR

TANK: MIX DESIGN #9 (SMALL FIBER)

CUSTOMIZED TANKS:
 FOR CUSTOM TANKS CONTACT
 WIESER CONCRETE

PRE-POUR:		DATE:	
SCALE: 3/16" = 1'-0"	REV.:	DRAWN BY: WCP	DATE: 00/00/00
POST-POUR:	REV.:	DATE: 00/00/00	FILE: w18000gi

WIESER CONCRETE
 W3716 US HWY 10, MAIDEN ROCK, WI 54750
 800-325-8456

W18000GI
 SEPTIC MANUAL

REVIEWED BY _____
 REVIEW DATE _____

**DRAWINGS SUBMITTED
 FOR APPROVAL**

APPROVED BY: _____
 APPROVAL DATE: _____
 PRODUCTS NEEDED BY: _____

SHEET NO.
 1
 OF
 1