

INLETS & OUTLET
VARY WITH LOCATIONS,
QUANTITY AND SIZE

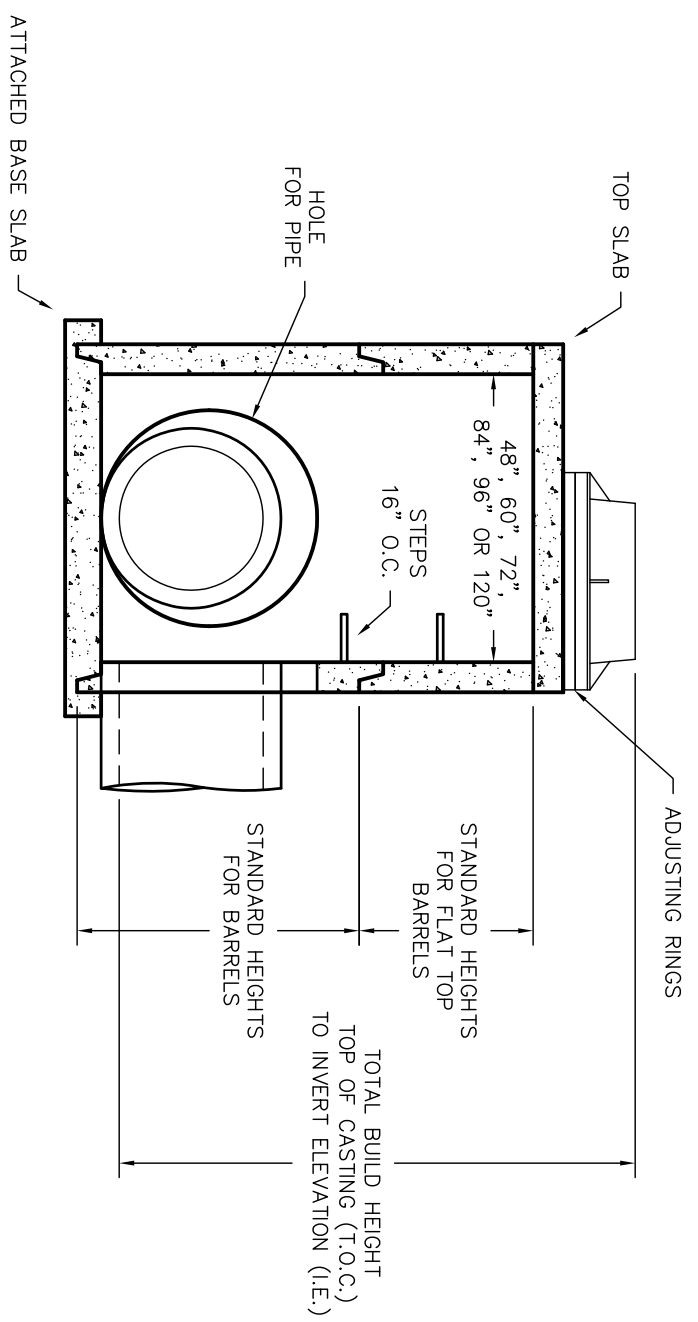

SPECIFICATIONS

MANHOLES PRODUCED PER ASTM C-478
 BARREL JOINT SEALANT: O-RING/BUTYL RUBBER
 PIPE CONNECTION: GROUDED, RUBBER GASKETED

STORM MANHOLE
 W/ ATTACHED BASE
 STANDARD DETAIL

WIESER CONCRETE
 W3716 US HWY10, MADISON ROCK, WI 54750
 800-325-8456

SCALE: NTS	REV NO.	DATE:
DRAWN BY:		
DATE:		
FILE:		

SHEET NO. 09