

# WLP2250 – MN TANK SPECIFICATIONS

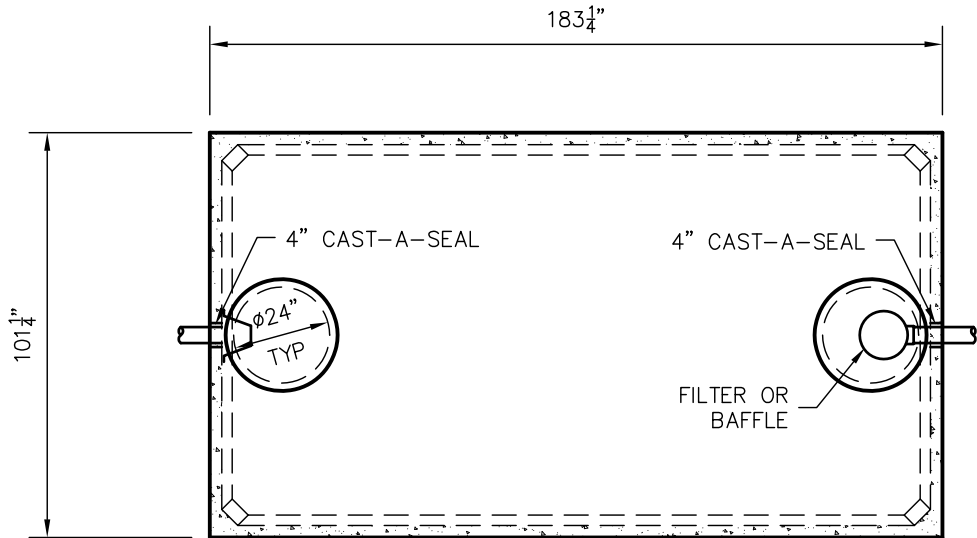

TOP VIEW

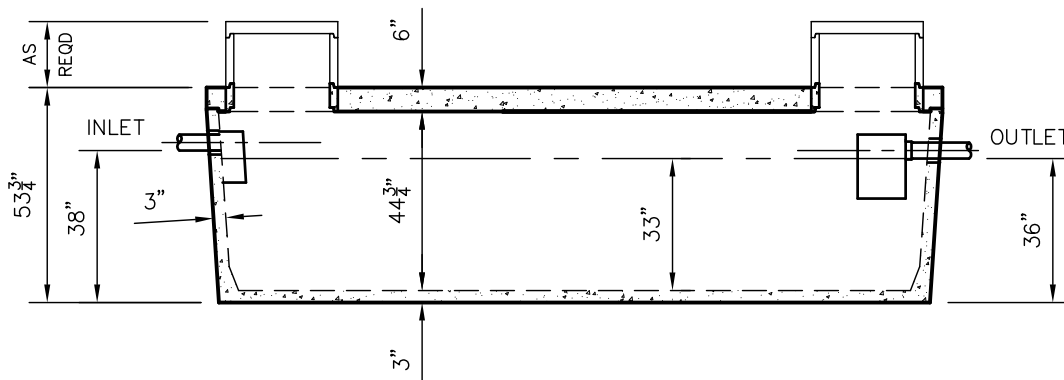

SIDE VIEW

**DIMENSIONS:**

WALL: 3"  
BOTTOM: 3"  
HEAVY – 5"

COVER: 6"  
MANHOLE: 24" I.D. PRECAST CONCRETE RISER  
HEIGHT: 53-3/4" O.D.  
LENGTH: 183-1/4" O.D.  
WIDTH: 101-1/4" O.D.  
BELOW INLET: 38" O.D.  
LIQUID LEVEL: 33"  
WEIGHT: TANK 12,560 LBS.  
WEIGHT: COVER 9,300 LBS.

INLET AND OUTLET:  
4" CAST-A-SEAL BOOT OR EQUAL

INLET AND OUTLET BAFFLE AND FILTER:  
AS SHOWN

LIQUID CAPACITY: 69.44 GAL/IN

HOLDING TANK:  
OUTLET HOLE PLUGGED  
ACTUAL CAPACITY: 2,639 GALLONS

LOADING DESIGN: 8' 0" UNSATURATED SOIL

TANK CAN BE USED AS:  
SEPTIC/ HOLDING/ PUMP OR SIPHON

COVER: MIX DESIGN #8 (NO FIBER)  
TANK: MIX DESIGN #9 (SMALL FIBER)

CUSTOMIZED TANKS:  
FOR CUSTOM TANKS CONTACT WIESER CONCRETE

TANKS ARE MANUFACTURED TO MEET OR EXCEED ASTM C-1227 REQUIREMENTS

**DRAWINGS SUBMITTED  
FOR APPROVAL**

APPROVED BY: \_\_\_\_\_  
APPROVAL DATE: \_\_\_\_\_  
PRODUCTS NEEDED BY: \_\_\_\_\_

PRE-FOUR:  
POST-POUR:

SCALE: 1/4" = 1'-0"  
REV. \_\_\_\_\_  
DATE: \_\_\_\_\_

DRAWN BY: WCP  
DATE: 00/00/00  
FILE: WLP2500

**WIESER CONCRETE**  
W3716 US HWY 10 MAIDEN ROCK, WI 54750  
800-325-8456

WLP2250  
SEPTIC MANUAL

SHEET NO.  
1 OF 1