

WLP2000-P TANK SPECIFICATIONS

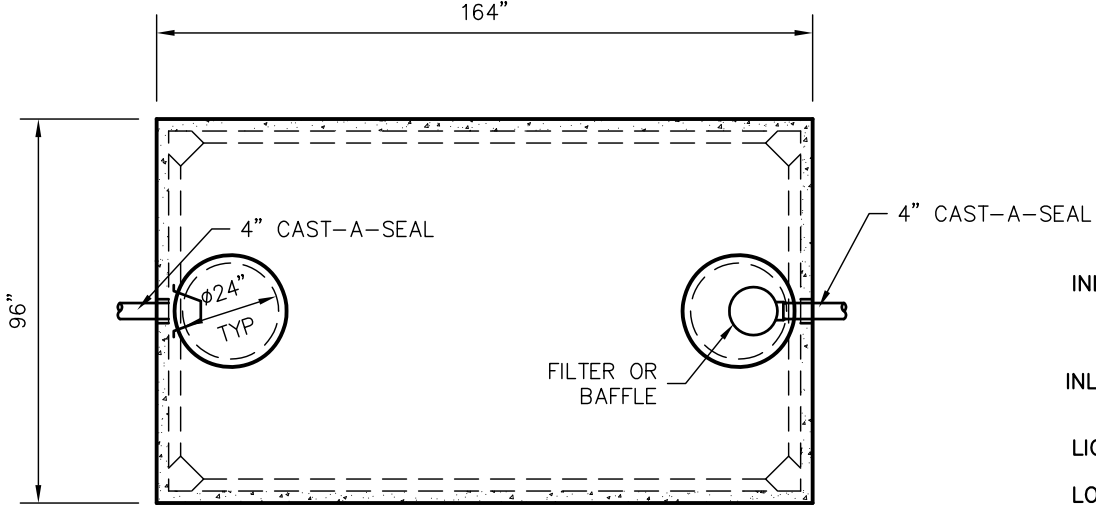

TOP VIEW

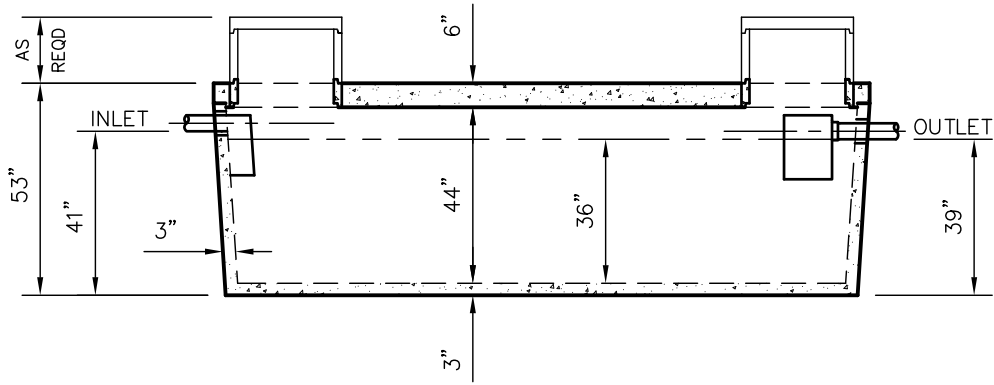

SIDE VIEW

DIMENSIONS:
 WALL: 3"
 BOTTOM: 3"
 HEAVY - 5"
 COVER: 6"
 MANHOLE: 24" I.D. PRECAST CONCRETE RISER
 HEIGHT: 53" O.D.
 LENGTH: 164" O.D.
 WIDTH: 96" O.D.
 BELOW INLET: 41" O.D.
 LIQUID LEVEL: 36"
 WEIGHT: TANK - 3" BOTTOM 20,700 LBS.
 TANK - 5" BOTTOM 23,500 LBS.

INLET AND OUTLET:
 4" CAST-A-SEAL BOOT OR EQUAL

INLET AND OUTLET Baffle AND FILTER:
 SEE DETAIL #10

LIQUID CAPACITY: 56.27 GAL/IN

LOADING DESIGN: 8' 0" UNSATURATED SOIL

HOLDING TANK:
 OUTLET HOLE PLUGGED
 ACTUAL CAPACITY: 2138 GALLONS

TANK CAN BE USED AS:
 SEPTIC/ HOLDING/ PUMP OR SIPHON

COVER: MIX DESIGN #8 (NO FIBER)
TANK: MIX DESIGN #9 (SMALL FIBER)

CUSTOMIZED TANKS:
 FOR CUSTOM TANKS CONTACT WIESER CONCRETE

PRE-POUR:	POST-POUR:
SCALE: 1/4"=1'-0"	REV. DATE:
DRAWN BY: WCP	DATE: 00/00/00
FILE: WLP2000-P-3	

WIESER CONCRETE
 W3716 US HWY 10 MAIDEN ROCK, WI 54750
 800-325-8456

WLP2000-P
 SEPTIC MANUAL

SHEET NO.
 1 OF 1

**DRAWINGS SUBMITTED
 FOR APPROVAL**

APPROVED BY: _____
 APPROVAL DATE: _____
 PRODUCTS NEEDED BY: _____

TANKS ARE MANUFACTURED TO MEET OR EXCEED ASTM C-1227 REQUIREMENTS