

WLP1800/1100 TANK SPECIFICATIONS

DIMENSIONS:
 WALL: 3"
 BOTTOM: 5"
 COVER: 6"
 MANHOLE: 24" I.D. PRECAST CONCRETE RISER
 HEIGHT: 62-3/4" O.D.
 LENGTH: 184" O.D.
 WIDTH: 102" O.D.
 BELOW INLET: 50" O.D.
 LIQUID LEVEL: 43"
 WEIGHT: TANK 18,017 LBS
 WEIGHT: COVER 9,300 LBS

INLET AND OUTLET:
 4" CAST-A-SEAL BOOT OR EQUAL

INLET AND OUTLET BAFFLE AND FILTER:
 WISCONSIN, SEE DETAIL #10
 (OTHER STATES SEE CHART)

LIQUID CAPACITY: 41.86 GAL/IN (SEPTIC)
 25.58 GAL/IN (PUMP)

LOADING DESIGN: 8'-0" UNSATURATED SOIL

TANK CAN BE USED AS:
 SEPTIC/SEPTIC, SEPTIC/PUMP
 OR SEPTIC/SIPHON

COVER: MIX DESIGN #8 (NO FIBER)
TANK: MIX DESIGN #9 (SMALL FIBER)

CUSTOMIZED TANKS:
 FOR CUSTOM TANKS CONTACT WIESER CONCRETE

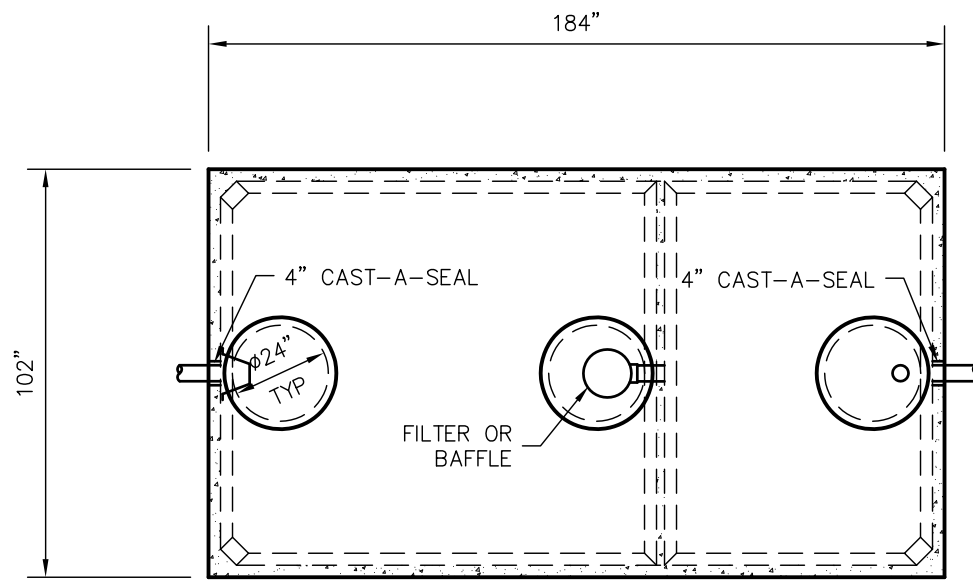

TOP VIEW

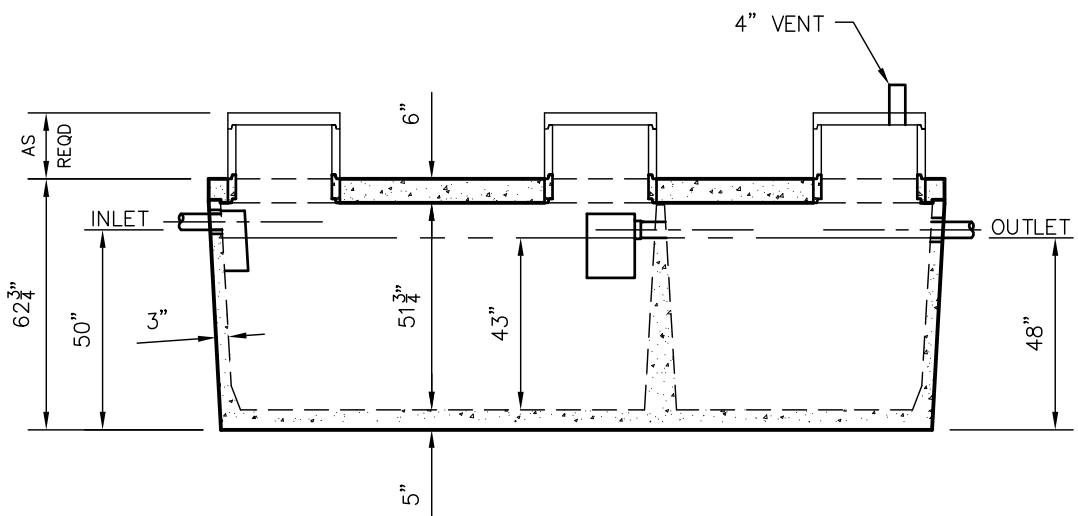

SIDE VIEW

TANKS ARE MANUFACTURED TO MEET OR EXCEED ASTM C-1227 REQUIREMENTS

**DRAWINGS SUBMITTED
FOR APPROVAL**

APPROVED BY: _____
 APPROVAL DATE: _____
 PRODUCTS NEEDED BY: _____

PRE-POUR:		SCALE: 1/4" = 1'-0"	REVIEW:	DATE:
DRAWN BY: WCP	DATE: 00/00/00	FILE: WLP1800-1100		
WIESER CONCRETE				
W3716 US HWY 10 MAIDEN ROCK, WI 54750				
800-325-8456				
WLP1800/1100	SEPTIC MANUAL			
SHEET NO.				
1 OF 1				