

WLP1650-FDL TANK SPECIFICATIONS

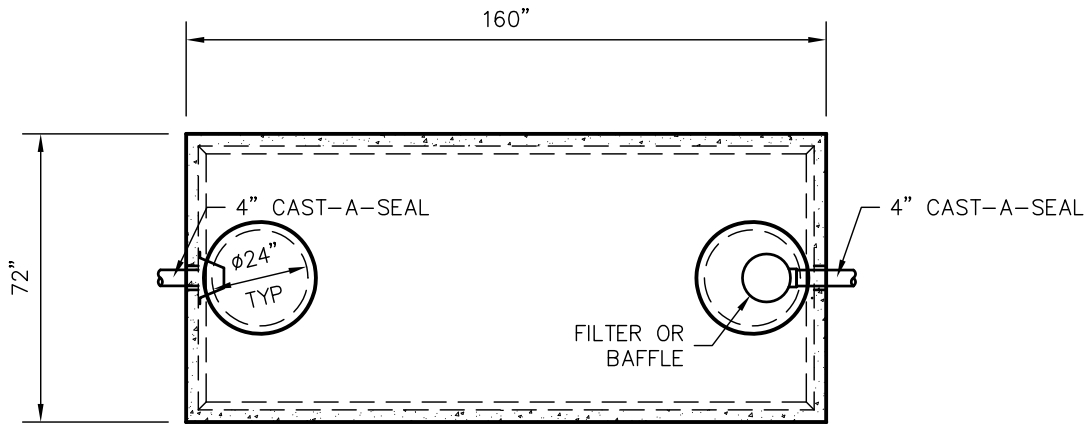

TOP VIEW

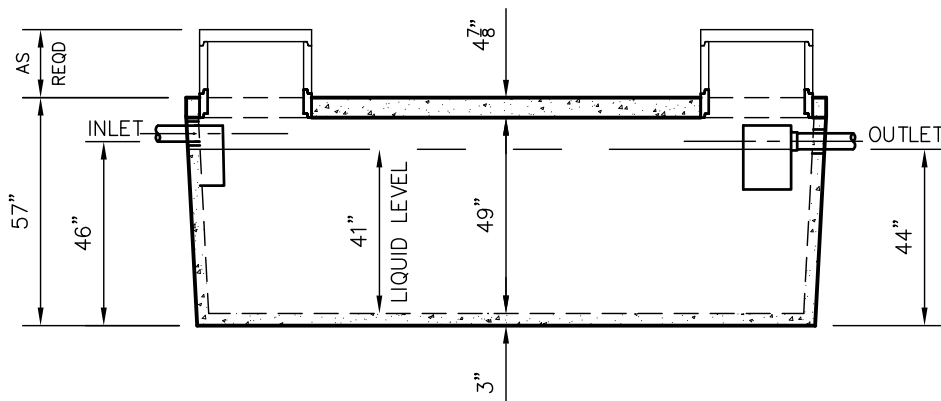

SIDE VIEW

DIMENSIONS:

WALL: 3"
 BOTTOM: 3"
 COVER: 5"
 MANHOLE: 24" I.D. PRECAST CONCRETE RISER
 HEIGHT: 57" O.D.
 LENGTH: 160" O.D.
 WIDTH: 72" O.D.
 BELOW INLET: 46" O.D.
 LIQUID LEVEL: 41"
 WEIGHT: 15,000 LBS.

INLET AND OUTLET:
 4" CAST-A-SEAL BOOT OR EQUAL

INLET AND OUTLET BAFFLE AND FILTER:
 SEE DETAIL #10

LIQUID CAPACITY: 42.00 GAL/IN

HOLDING TANK:
 OUTLET HOLE PLUGGED
 ACTUAL CAPACITY: 1806 GALLONS

LOADING DESIGN: 8' 0" UNSATURATED SOIL

TANK CAN BE USED AS:
 SEPTIC/ HOLDING/ PUMP OR SIPHON

COVER: MIX DESIGN #8 (NO FIBER)
 TANK: MIX DESIGN #9 (SMALL FIBER)

CUSTOMIZED TANKS:
 FOR CUSTOM TANKS CONTACT WIESER CONCRETE

PRE-POUR:
POST-POUR:

SCALE: 1/4"=1'-0"
REV.
DATE:

DRAWN BY: WCP
DATE: 00/00/00

FILE: WLP1650-FDL

WIESER CONCRETE
 W3716 US HWY 10 MAIDEN ROCK, WI 54750
 800-325-8456

WLP1650-FDL
SEPTIC MANUAL

SHEET NO.
1 OF 1

**DRAWINGS SUBMITTED
FOR APPROVAL**

APPROVED BY: _____
 APPROVAL DATE: _____
 PRODUCTS NEEDED BY: _____