

WLP1645-MR TANK SPECIFICATIONS

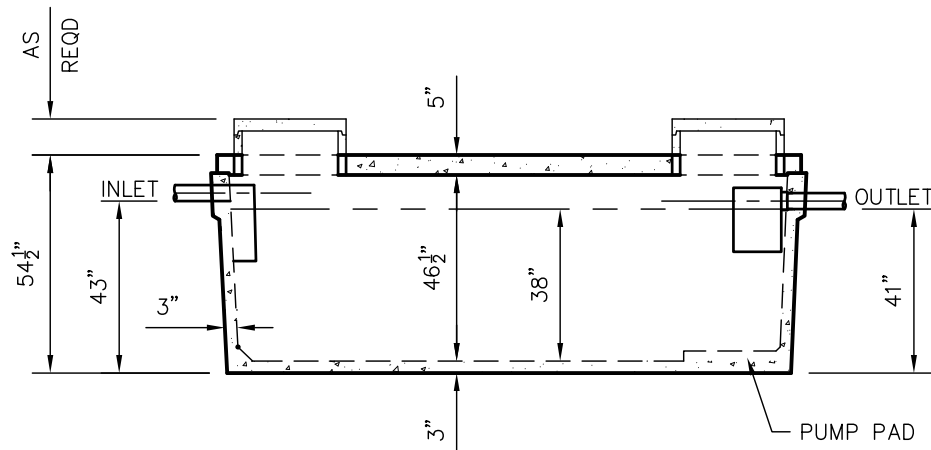
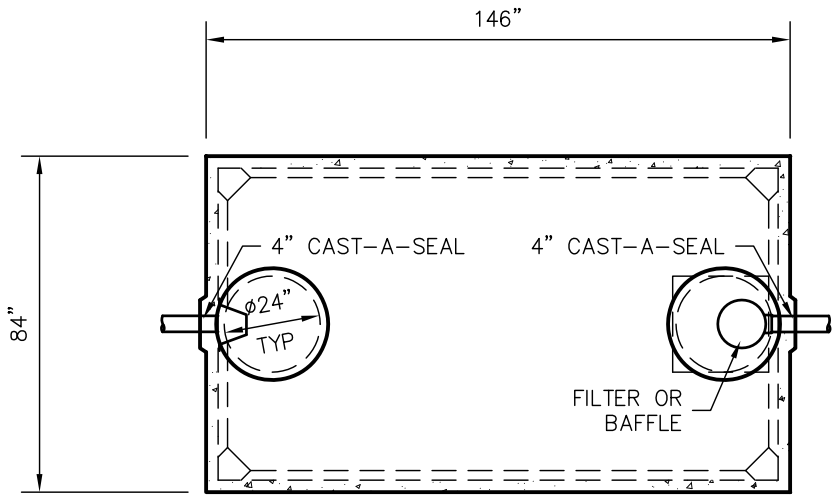

DIMENSIONS:
 WALL: 3"
 BOTTOM: SEPTIC 3"
 COVER: 5"
 MANHOLE: 24" I.D. PRECAST CONCRETE RISER
 HEIGHT: 54 1/2" O.D.
 LENGTH: 146" O.D.
 WIDTH: 84" O.D.
 BELOW INLET: 43" O.D.
 LIQUID LEVEL: 38"
 WEIGHT: 14,000 LBS.

INLET AND OUTLET:
 4" CAST-A-SEAL BOOT OR EQUAL
 GASKET, CAST-A-SEAL BOOT OR EQUAL

INLET AND OUTLET BAFFLE AND FILTER:
 WISCONSIN, SEE DETAIL #10
 (OTHER STATES SEE CHART)

LIQUID CAPACITY: 43.32 GAL/IN

HOLDING TANK:
 OUTLET HOLE PLUGGED
 ACTUAL CAPACITY: 1,733 GALLONS

LOADING DESIGN: 8' 0" UNSATURATED SOIL

TANK CAN BE USED AS:
 SEPTIC/ HOLDING/ PUMP OR SIPHON

COVER: MIX DESIGN #8 (NO FIBER)
TANK: MIX DESIGN #10 (STRUCTURAL FIBER)

CUSTOMIZED TANKS:
 FOR CUSTOM TANKS CONTACT WIESER CONCRETE

**DRAWINGS SUBMITTED
FOR APPROVAL**

APPROVED BY: _____
 APPROVAL DATE: _____
 PRODUCTS NEEDED BY: _____

TANKS ARE MANUFACTURED TO MEET OR EXCEED ASTM C-1227 REQUIREMENTS

PRE-POUR:		SCALE: 1/4" = 1'-0"	
DRAWN BY: WCP	REV.:	DATE:	POST-POUR:
DATE: 00/00/00	FILE: WLP1645-MR		
WIESER CONCRETE			
W3716 US HWY 10 MAIDEN ROCK, WI 54750			
800-325-8456			
WLP1645-MR	SEPTIC MANUAL		
			SHEET NO.
			1 OF 1