

WLP1600-P TANK SPECIFICATIONS

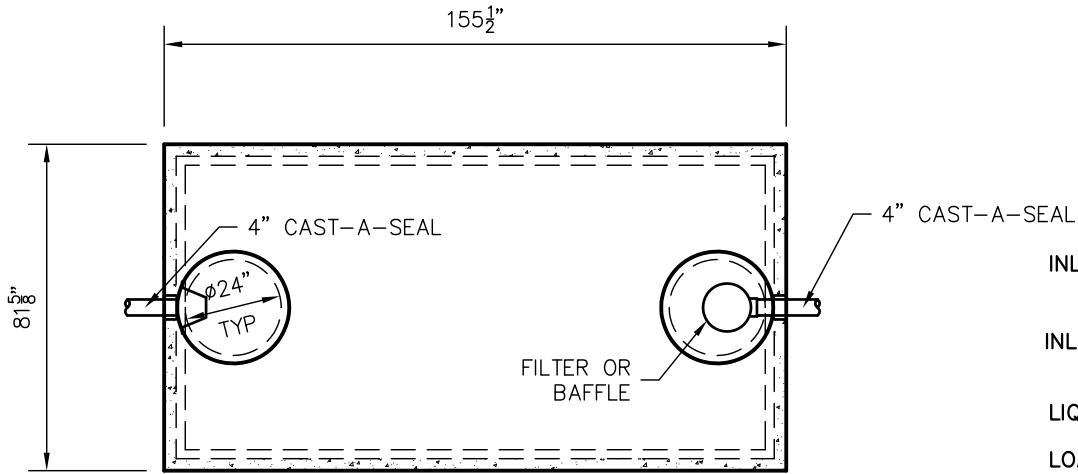

TOP VIEW

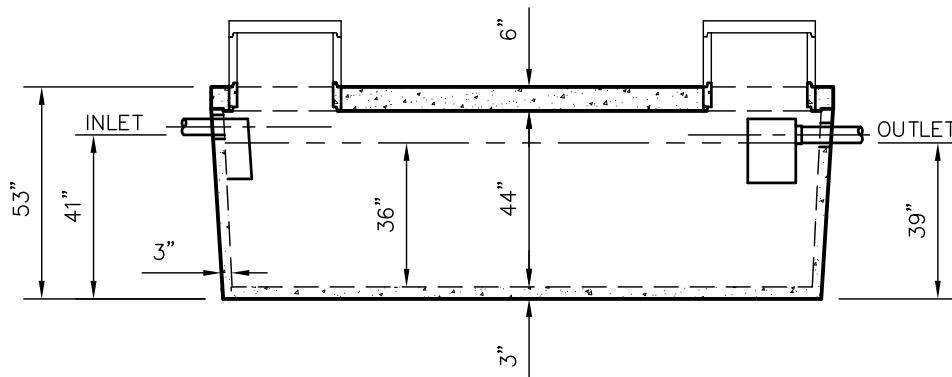

SIDE VIEW

DIMENSIONS:

WALL: 3"
 BOTTOM: 3"
 COVER: 6"
 MANHOLE: 24" I.D. PRECAST CONCRETE RISER
 HEIGHT: 53" O.D.
 LENGTH: 155-1/2" O.D.
 WIDTH: 81-5/8" O.D.
 BELOW INLET: 41" O.D.
 LIQUID LEVEL: 36"
 WEIGHT: 16,650 LBS.

INLET AND OUTLET:
 4" CAST-A-SEAL BOOT OR EQUAL

INLET AND OUTLET BAFFLE AND FILTER:
 SEE DETAIL #10

LIQUID CAPACITY: 45.41 GAL/IN

LOADING DESIGN: 8' 0" UNSATURATED SOIL

HOLDING TANK:
 OUTLET HOLE PLUGGED
 ACTUAL CAPACITY: 1726 GALLONS

TANK CAN BE USED AS:
 SEPTIC/ HOLDING/ PUMP OR SIPHON

COVER: MIX DESIGN #8 (NO FIBER)
 TANK: MIX DESIGN #10 (STRUCTURAL FIBER)

CUSTOMIZED TANKS:
 FOR CUSTOM TANKS CONTACT WIESER CONCRETE

TANKS ARE MANUFACTURED TO MEET OR EXCEED ASTM C-1227 REQUIREMENTS

**DRAWINGS SUBMITTED
FOR APPROVAL**

APPROVED BY: _____
 APPROVAL DATE: _____
 PRODUCTS NEEDED BY: _____

PRE-FOUR:	SCALE: 1/4"=1'-0"	REV.:	POST-POUR:
DRAWN BY: WCP	DATE: 00/00/00	REV.:	DATE:
WIESER CONCRETE		W3716 US HWY 10 MAIDEN ROCK, WI 54750	
WLP1600-P		800-325-8456	
SEPTIC MANUAL			
SHEET NO.		1 OF 1	