

WLP1000-MR TANK SPECIFICATIONS

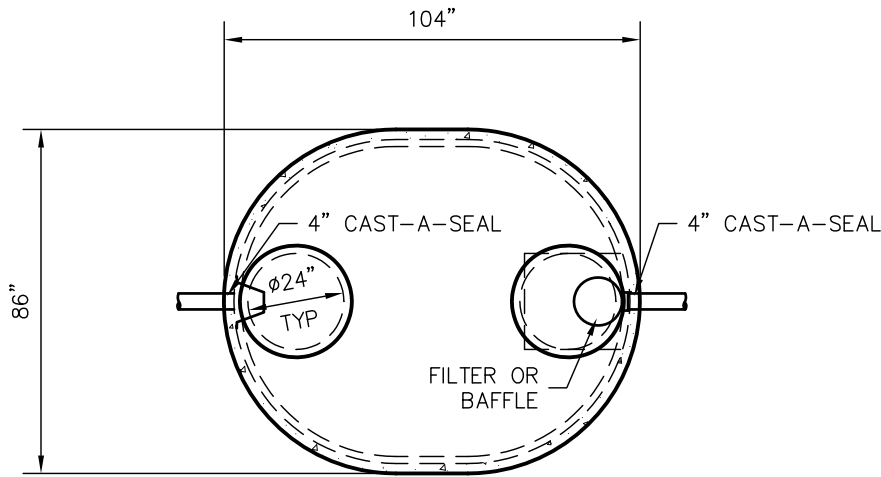

TOP VIEW

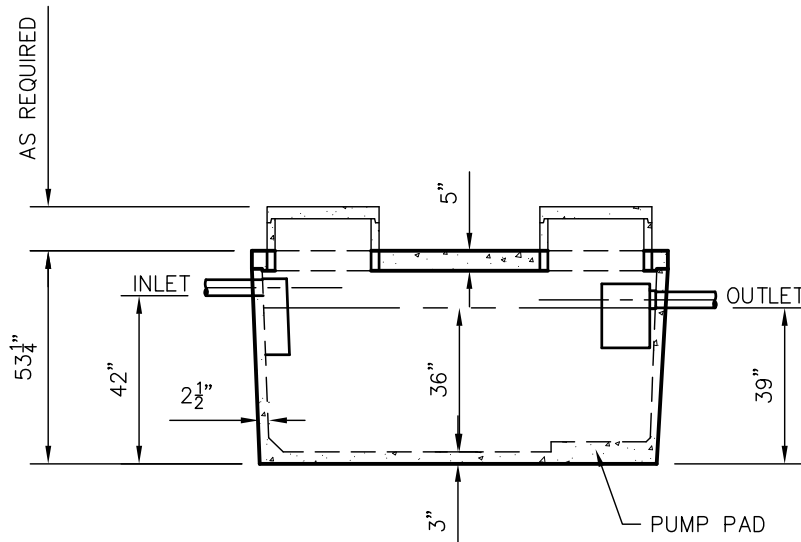

SIDE VIEW

DIMENSIONS:

WALL: 2 1/2"
BOTTOM: SEPTIC 3"

COVER: 4"
MANHOLE: 24" I.D. PRECAST CONCRETE RISER
HEIGHT: FLAT COVER 53 1/4" O.D.
LENGTH: 104" O.D.
WIDTH: 86" O.D.
BELOW INLET: 42" O.D.
LIQUID LEVEL: 36"
WEIGHT: 6,790 LBS.

INLET AND OUTLET:

4" CAST-A-SEAL BOOT OR EQUAL
GASKET, CAST-A-SEAL BOOT OR EQUAL

INLET AND OUTLET BAFFLE AND FILTER:

WISCONSIN, SEE DETAIL #10
(OTHER STATES SEE CHART)

LIQUID CAPACITY: 27.83 GAL/IN

HOLDING TANK:

OUTLET HOLE PLUGGED
ACTUAL CAPACITY: 1,085 GALLONS

LOADING DESIGN: 8' 0" UNSATURATED SOIL

TANK CAN BE USED AS:

SEPTIC/ HOLDING/ PUMP OR SIPHON

COVER: MIX DESIGN #8 (NO FIBER)

TANK: MIX DESIGN #10 (STRUCTURAL FIBER)

CUSTOMIZED TANKS:

FOR CUSTOM TANKS CONTACT WIESER CONCRETE

TANKS ARE MANUFACTURED TO MEET OR EXCEED ASTM C-1227 REQUIREMENTS

**DRAWINGS SUBMITTED
FOR APPROVAL**

APPROVED BY: _____

APPROVAL DATE: _____

PRODUCTS NEEDED BY: _____

PRE-POUR:		SCALE: 1/4" = 1'-0"	
POST-POUR:		REV. DATE:	
DRAWN BY: WCP		DATE: 00/00/00	
		FILE: WLP1000-MR	
WIESER CONCRETE			
W3716 US HWY 10 MAIDEN ROCK, WI 54750			
800-325-8456			
WLP1000-MR	SEPTIC MANUAL		
	SHEET NO.		
	1 OF 1		