

WLP1000-FDL TANK SPECIFICATIONS

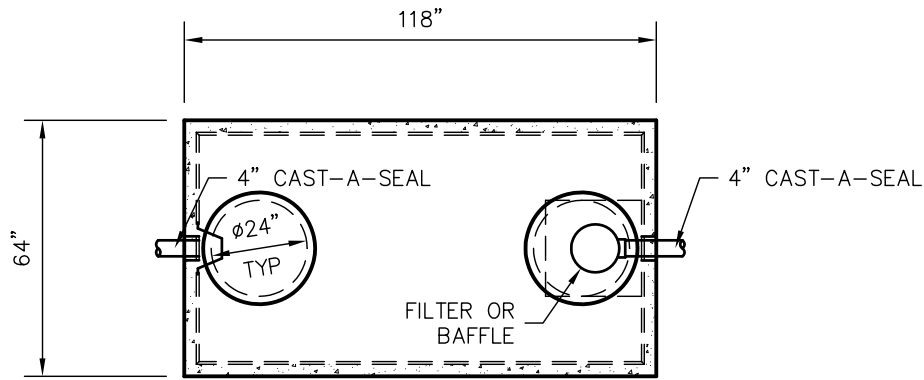

TOP VIEW

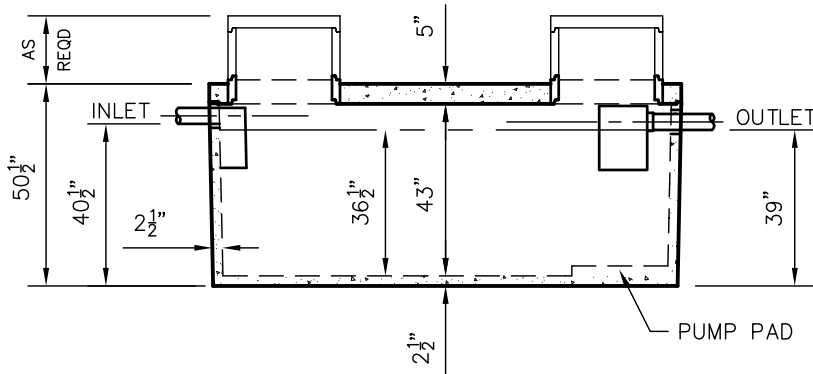

SIDE VIEW

DIMENSIONS:

WALL: 2-1/2"
 BOTTOM: 2-1/2"
 COVER: 5"
 MANHOLE: 24" I.D. PRECAST CONCRETE RISER
 HEIGHT: 50 1/2" O.D.
 LENGTH: 118" O.D.
 WIDTH: 64" O.D.
 BELOW INLET: 40 1/2" O.D.
 LIQUID LEVEL: 36 1/2"
 WEIGHT: 8,000 LBS.

INLET AND OUTLET:
 4" CAST-A-SEAL BOOT OR EQUAL

INLET AND OUTLET BAFFLE AND FILTER:
 SEE DETAIL #10

LIQUID CAPACITY: 28.00 GAL/IN

HOLDING TANK:
 OUTLET HOLE PLUGGED
 ACTUAL CAPACITY: 1064 GALLONS

LOADING DESIGN: 8' 0" UNSATURATED SOIL

TANK CAN BE USED AS:
 SEPTIC/ HOLDING/ PUMP OR SIPHON

COVER: MIX DESIGN #8 (NO FIBER)
 TANK: MIX DESIGN #9 (SMALL FIBER)

CUSTOMIZED TANKS:
 FOR CUSTOM TANKS CONTACT WIESER CONCRETE

TANKS ARE MANUFACTURED TO MEET OR EXCEED ASTM C-1227 REQUIREMENTS

**DRAWINGS SUBMITTED
FOR APPROVAL**

APPROVED BY: _____
 APPROVAL DATE: _____
 PRODUCTS NEEDED BY: _____

PRE-POUR:		SCALE: 1/4"=1'-0"	
DRAWN BY: WCP	DATE: 00/00/00	REV:	DATE:
FILE: WLP1000-FDL	<b style="font-size: 2em;">WIESER CONCRETE W3716 US HWY 10 MAIDEN ROCK, WI 54750 800-325-8456		
WLP1000-FDL	SEPTIC MANUAL		
SHEET NO.	1 OF 1		