

WLP1000/650-FDL TRIPLE TANK SPECIFICATIONS

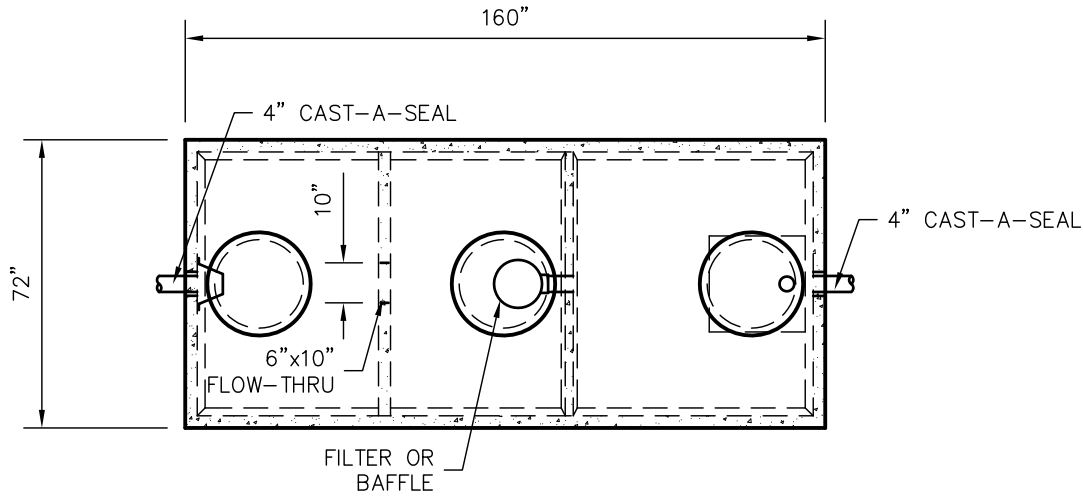

TOP VIEW

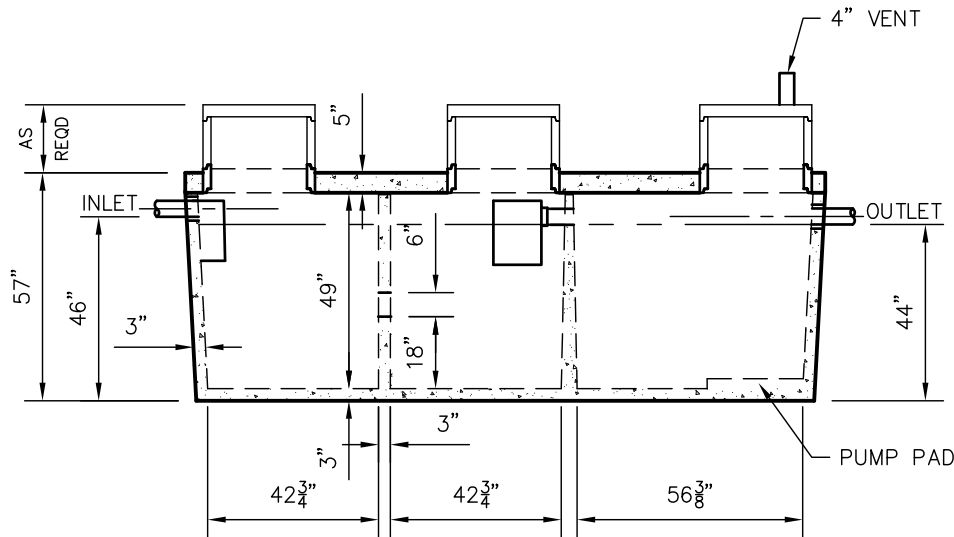

SIDE VIEW

TANKS ARE MANUFACTURED TO MEET OR EXCEED ASTM C-1227 REQUIREMENTS

DIMENSIONS:

WALL: 3"
 BOTTOM: 3"
 COVER: 5"
 MANHOLE: 24" I.D. PRECAST CONCRETE RISER
 HEIGHT: 57"
 LENGTH: 160" O.D.
 WIDTH: 72" O.D.
 BELOW INLET: 46" O.D.
 LIQUID LEVEL: 41"
 WEIGHT: 15,000 LBS.

INLET AND OUTLET:
 4" CAST-A-SEAL BOOT OR EQUAL

INLET AND OUTLET BAFFLE AND FILTER:
 SEE DETAIL #10

LIQUID CAPACITY: 12.37 GAL/IN (SEPTIC)
 12.37 GAL/IN (SEPTIC)
 15.93 GAL/IN (PUMP)

LOADING DESIGN: 8' 0" UNSATURATED SOIL

TANK CAN BE USED AS:
 SEPTIC/SEPTIC, SEPTIC/PUMP
 OR SEPTIC/SIPHON

COVER: MIX DESIGN #8 (NO FIBER)
 TANK: MIX DESIGN #9 (SMALL FIBER)

CUSTOMIZED TANKS:
 FOR CUSTOM TANKS CONTACT WIESER CONCRETE

**DRAWINGS SUBMITTED
 FOR APPROVAL**

APPROVED BY: _____
 APPROVAL DATE: _____
 PRODUCTS NEEDED BY: _____

SCALE: 1/4"=1'-0"	PRE-POUR:
REV. _____	POST-POUR:
DATE: 00/00/00	
DRAWN BY: WCP	
FILE: WLP1000-650 FDL	

WIESER CONCRETE
 W3716 US HWY 10 MAIDEN ROCK, WI 54750
 800-325-8456

WLP1000/650-FDL TRIPLE
 SEPTIC MANUAL

SHEET NO.
 1 OF 1