

# WLP1000/600-P TANK SPECIFICATIONS

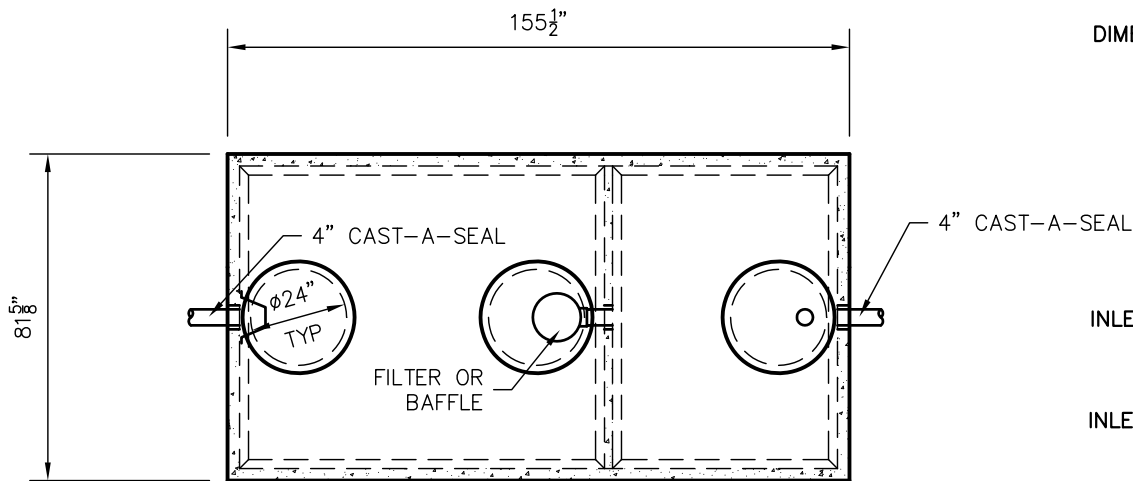

TOP VIEW

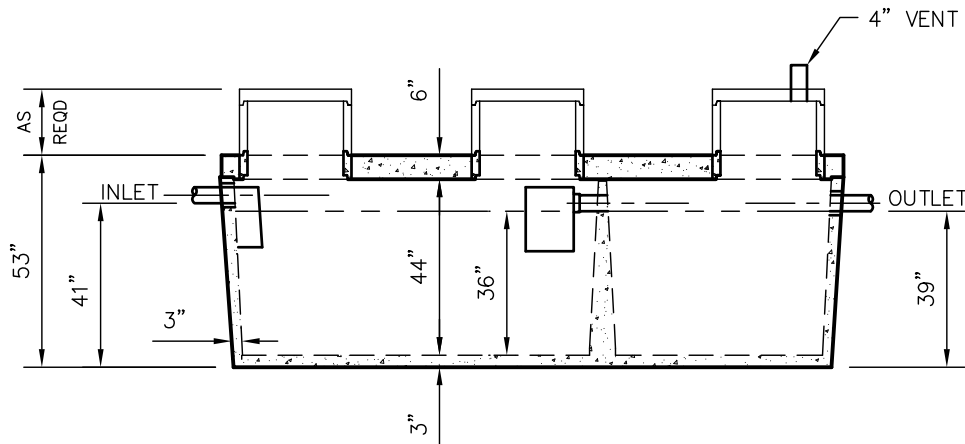

SIDE VIEW

**DIMENSIONS:**

- WALL: 3"
- BOTTOM: 3"
- COVER: 6"
- MANHOLE: 24" I.D. PRECAST CONCRETE RISER
- HEIGHT: 53" O.D.
- LENGTH: 155-1/2" O.D.
- WIDTH: 81-5/8" O.D.
- BELOW INLET: 41" O.D.
- LIQUID LEVEL: 36"
- WEIGHT: 17,200 LBS

INLET AND OUTLET:  
4" CAST-A-SEAL BOOT OR EQUAL

INLET AND OUTLET BAFFLE AND FILTER:  
SEE DETAIL #10

LIQUID CAPACITY: 27.88 GAL/IN (SEPTIC)  
16.83 GAL/IN (PUMP)

LOADING DESIGN: 8'-0" UNSATURATED SOIL

TANK CAN BE USED AS:  
SEPTIC/SEPTIC, SEPTIC/PUMP  
OR SEPTIC/SIPHON

COVER: MIX DESIGN #8 (NO FIBER)  
TANK: MIX DESIGN #10 (STRUCTURAL FIBER)

CUSTOMIZED TANKS:  
FOR CUSTOM TANKS CONTACT WIESER CONCRETE

TANKS ARE MANUFACTURED TO MEET OR EXCEED ASTM C-1227 REQUIREMENTS

**DRAWINGS SUBMITTED  
FOR APPROVAL**

APPROVED BY: \_\_\_\_\_

APPROVAL DATE: \_\_\_\_\_

PRODUCTS NEEDED BY: \_\_\_\_\_

PRE-POUR:		SCALE: 1/4"=1'-0"	
DRAWN BY: WCP	DATE: 00/00/00	REV:	DATE:
<b>WIESER CONCRETE</b>		W3716 US HWY 10 MAIDEN ROCK, WI 54750	
WLP1000/600-P		800-325-8456	
SEPTIC MANUAL		SHEET NO.	
1		OF 1	