

WLP1000/600-P TRIPLE TANK SPECIFICATIONS

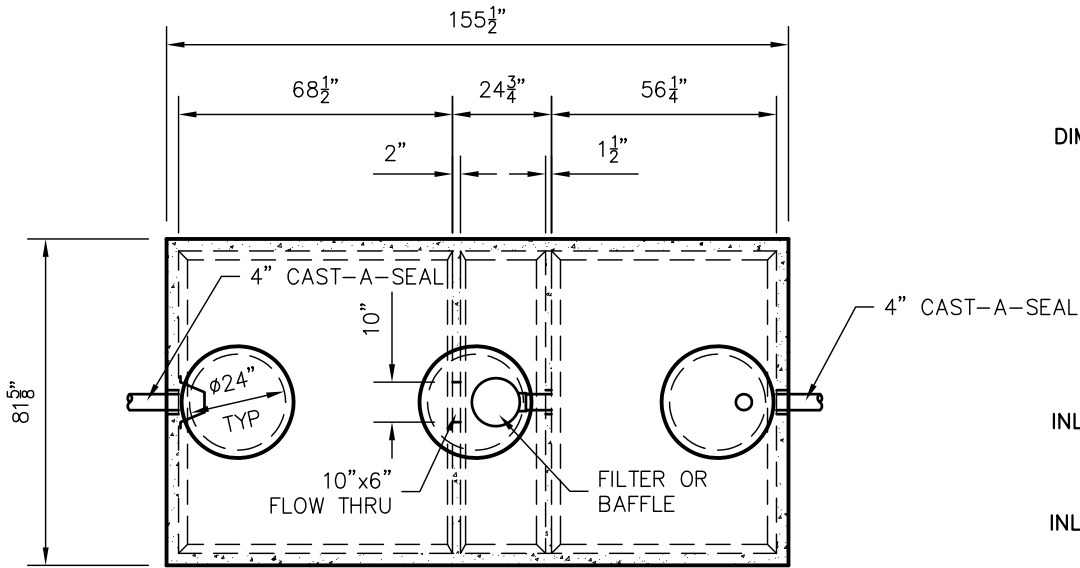

TOP VIEW

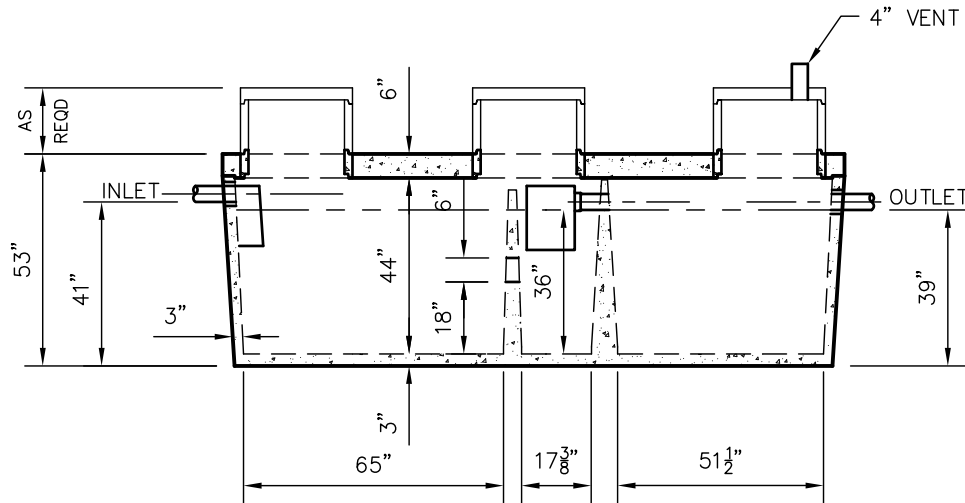

SIDE VIEW

DIMENSIONS:

WALL: 3"
 BOTTOM: 3"
 COVER: 6"
 MANHOLE: 24" I.D. PRECAST CONCRETE RISER
 HEIGHT: 53" O.D.
 LENGTH: 155-1/2" O.D.
 WIDTH: 81-5/8" O.D.
 BELOW INLET: 41" O.D.
 LIQUID LEVEL: 36"
 WEIGHT: 17,200 LBS

INLET AND OUTLET:
 4" CAST-A-SEAL BOOT OR EQUAL

INLET AND OUTLET BAFFLE AND FILTER:
 SEE DETAIL #10

LIQUID CAPACITY: 22.03 GAL/IN (SEPTIC)
 5.85 GAL/IN (SEPTIC)
 16.83 GAL/IN (PUMP)

LOADING DESIGN: 8'-0" UNSATURATED SOIL

TANK CAN BE USED AS:
 SEPTIC/SEPTIC, SEPTIC/PUMP
 OR SEPTIC/SIPHON

COVER: MIX DESIGN #8 (NO FIBER)
 TANK: MIX DESIGN #10 (STRUCTURAL FIBER)

CUSTOMIZED TANKS:
 FOR CUSTOM TANKS CONTACT WIESER CONCRETE

**DRAWINGS SUBMITTED
 FOR APPROVAL**

APPROVED BY: _____
 APPROVAL DATE: _____
 PRODUCTS NEEDED BY: _____

TANKS ARE MANUFACTURED TO MEET OR EXCEED ASTM C-1227 REQUIREMENTS

PRE-FOUR:

SCALE: 1/4" = 1'-0"

REV. DATE:

DRAWN BY: WCP
 DATE: 00/00/00

FILE: WLP1000-600 P

WIESER CONCRETE
 W3716 US HWY 10 MAIDEN ROCK, WI 54750
 800-325-8456

WLP1000/600-P TRIPLE
 SEPTIC MANUAL

SHEET NO.
 1 OF 1