

WEHD1250 GREASE INTERCEPTOR TANK SPECIFICATIONS

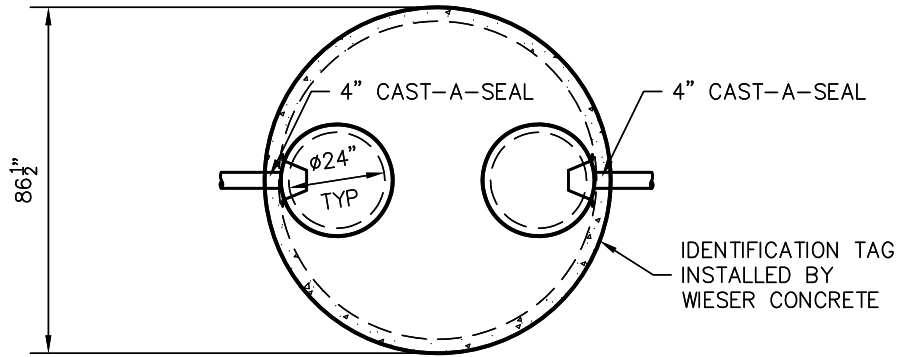

TOP VIEW

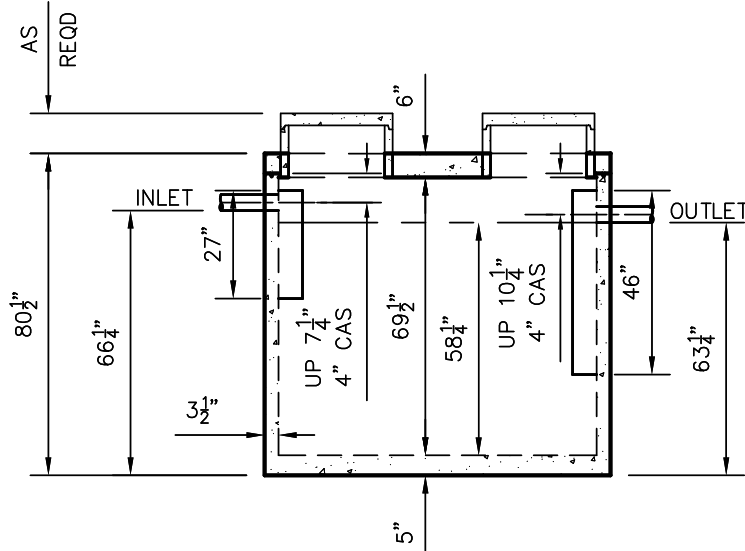

SIDE VIEW

DIMENSIONS:

WALL: 3 1/2"
 BOTTOM: 5"
 COVER: 6"
 MANHOLE: 24" I.D. PRECAST CONCRETE RISER
 HEIGHT: 80 1/2" O.D.
 OUTSIDE DIAMETER: 86 1/2" O.D.
 BELOW INLET: 66 1/4" O.D.
 LIQUID LEVEL: 58 1/4"
 WEIGHT: TANK 8,100 LBS.
 WEIGHT: COVER 3,000 LBS.

INLET AND OUTLET:
 4" CAST-A-SEAL BOOT, GASKET OR EQUAL

INLET AND OUTLET BAFFLE:
 AS SHOWN

LIQUID CAPACITY: 21.48 GAL/IN

LOADING DESIGN: 12'-0" UNSATURATED SOIL / HS-20

TANK CAN BE USED AS:
 EXTRA HEAVY DUTY GREASE INTERCEPTOR

COVER: MIX DESIGN #8 (NO FIBER)
 TANK: MIX DESIGN #8 (NO FIBER)

CUSTOMIZED TANKS:
 FOR CUSTOM TANKS CONTACT WESER CONCRETE

PRE-FOUR:
 POST-POUR:

SCALE: 1/4"=1'-0"
 REV. DATE:

DRAWN BY: WCP
 DATE: 00/00/00

FILE: WEHD1250

WESER CONCRETE
 W3716 US HWY 10 MAIDEN ROCK, WI 54750
 800-325-8456

REVIEWED BY _____ REVIEWED BY _____
 REVIEW DATE _____ REVIEW DATE _____

**DRAWINGS SUBMITTED
 FOR APPROVAL**

APPROVED BY: _____
 APPROVAL DATE: _____
 PRODUCTS NEEDED BY: _____

WEHD1250

SEPTIC MANUAL

SHEET NO.
 1 OF 1