

WEHD1250 TANK SPECIFICATIONS

DIMENSIONS:

WALL: 3 1/2"
 BOTTOM: 5"
 COVER: 6"
 MANHOLE: 24" I.D. PRECAST CONCRETE RISER
 HEIGHT: 80 1/2" O.D.
 OUTSIDE DIAMETER: 86 1/2" O.D.
 BELOW INLET: 66 1/4" O.D.
 LIQUID LEVEL: 58 1/4"
 WEIGHT: TANK 8,100 LBS.
 WEIGHT: COVER 3,000 LBS.

INLET AND OUTLET:
 4" CAST-A-SEAL BOOT, GASKET OR EQUAL

INLET AND OUTLET Baffle AND FILTER:
 WISCONSIN, SEE DETAIL #10
 (OTHER STATES SEE CHART)

LIQUID CAPACITY: 21.48 GAL/IN

HOLDING TANK:
 OUTLET HOLE PLUGGED
 ACTUAL CAPACITY: 1,315 GALLONS

LOADING DESIGN: 12' 0" UNSATURATED SOIL / HS-20

TANK CAN BE USED AS:
 SEPTIC / HOLDING / PUMP OR SIPHON

COVER: MIX DESIGN #8 (NO FIBER)
 TANK: MIX DESIGN #8 (NO FIBER)

CUSTOMIZED TANKS:
 FOR CUSTOM TANKS CONTACT WIESER CONCRETE

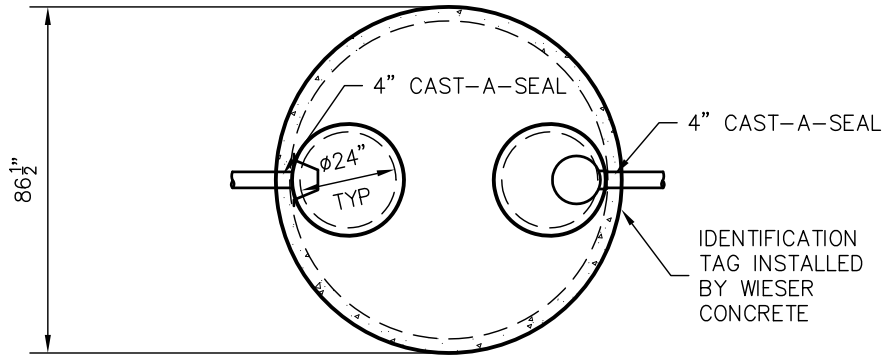

TOP VIEW

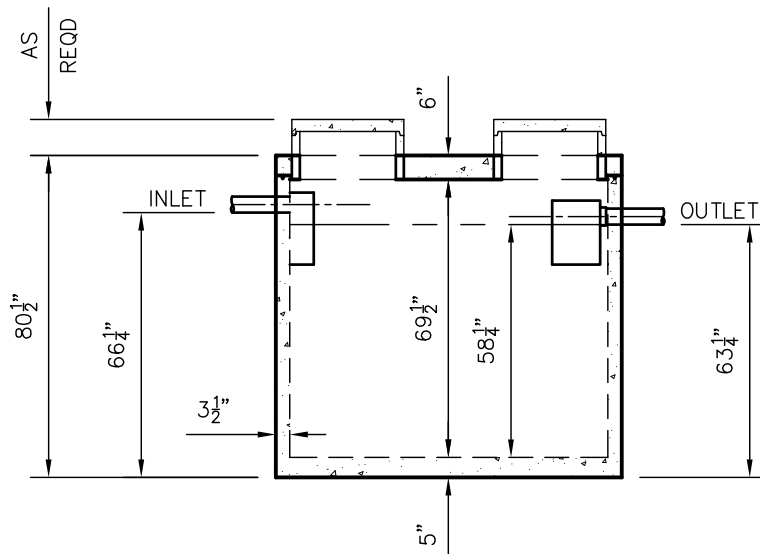

SIDE VIEW

TANKS ARE MANUFACTURED TO MEET OR EXCEED ASTM C-1227 REQUIREMENTS

DRAWINGS SUBMITTED FOR APPROVAL	
APPROVED BY: _____	_____
APPROVAL DATE: _____	_____
PRODUCTS NEEDED BY: _____	_____

WEHD1250	SCALE: 1/4" = 1'-0"	PRE-FOUR:	POST-POUR:
SEPTIC MANUAL	DRAWN BY: WCP	REV. DATE:	SCALE: 1/4" = 1'-0"
WIESER CONCRETE	DATE: 00/00/00	FILE: WEHD1250	
W3716 US HWY 10 MAIDEN ROCK, WI 54750			
800-325-8456			
SHEET NO.		1 OF 1	