

WEHD1200/800 TANK SPECIFICATIONS

DIMENSIONS:

WALL: 6"
 BOTTOM: 6"
 COVER: 6"
 MANHOLE: 24" I.D. PRECAST CONCRETE RISER
 HEIGHT: 66" O.D.
 LENGTH: 156" O.D.
 WIDTH: 84" O.D.
 BELOW INLET: 54" O.D.
 LIQUID LEVEL: 46"
 WEIGHT: TANK 19,400 LBS.
 WEIGHT: COVER 6,800 LBS.

INLET AND OUTLET:

4" CAST-A-SEAL BOOT, GASKET OR EQUAL

INLET AND OUTLET BAFFLE AND FILTER:

WISCONSIN, SEE DETAIL #10
 (OTHER STATES SEE CHART)

LIQUID CAPACITY: 26.49 GAL/IN (FIRST COMPARTMENT)
 17.45 GAL/IN (SECOND COMPARTMENT)

LOADING DESIGN: 12' 0" UNSATURATED SOIL / HS-20

HOLDING TANK:

OUTLET HOLE PLUGGED
 ACTUAL CAPACITY: 2,109 GALLONS

TANK CAN BE USED AS:

SEPTIC/SEPTIC, SEPTIC/PUMP
 SEPTIC/SIPHON, OR HOLDING

COVER: MIX DESIGN #8 (NO FIBER)
 TANK: MIX DESIGN #8 (NO FIBER)

CUSTOMIZED TANKS:

FOR CUSTOM TANKS CONTACT WIESER CONCRETE

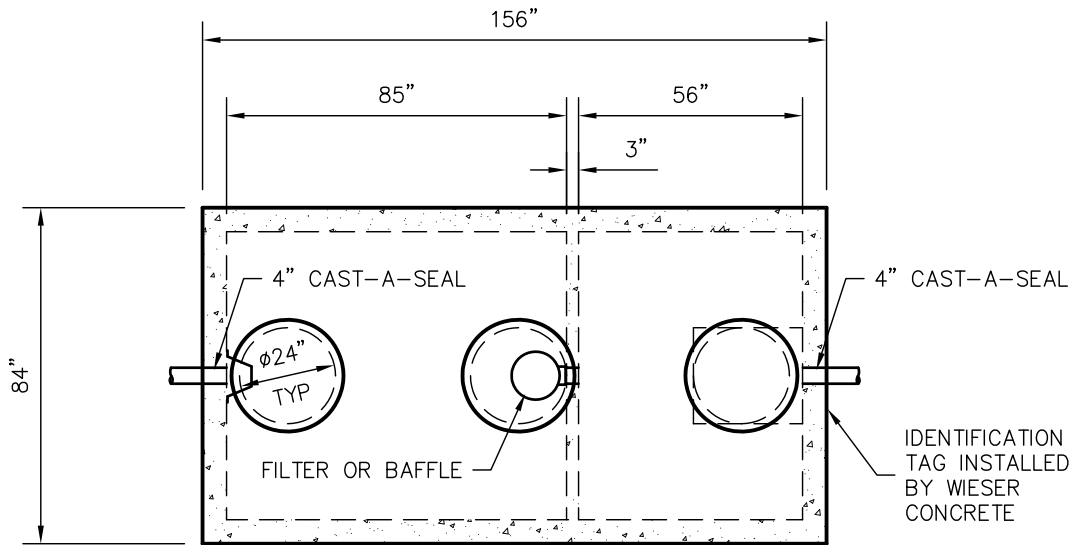

TOP VIEW

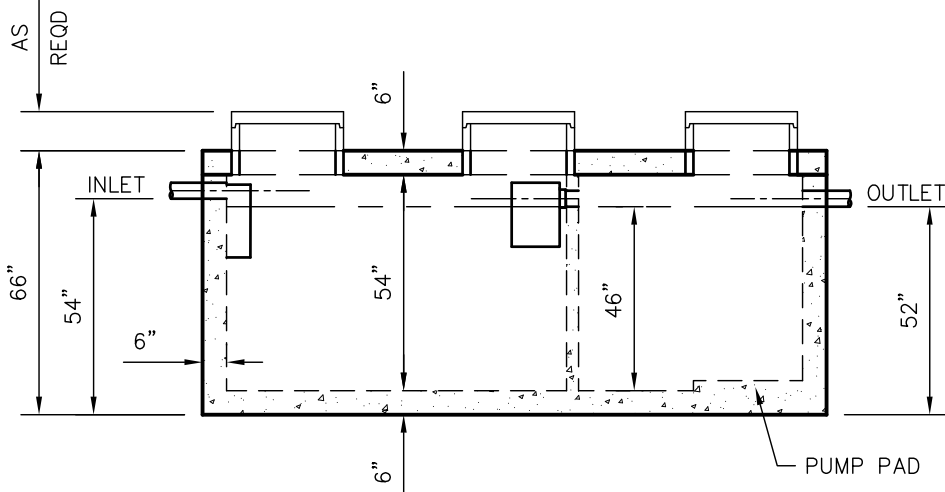

SIDE VIEW

TANKS ARE MANUFACTURED TO MEET OR EXCEED ASTM C-1227 REQUIREMENTS

**DRAWINGS SUBMITTED
FOR APPROVAL**

APPROVED BY: _____
 APPROVAL DATE: _____
 PRODUCTS NEEDED BY: _____

PRE-POUR:

POST-POUR:

SCALE: 1/4" = 1'-0"

REV. DATE:

DRAWN BY: WCP

DATE: 00/00/00

FILE: WEHD1200-800

WIESER CONCRETE
 W3716 US HWY 10 MAIDEN ROCK, WI 54750

800-325-8456

WEHD1200/800

SEPTIC MANUAL

SHEET NO.

1 OF 1