

W850-P GREASE INTERCEPTOR TANK SPECIFICATIONS

DIMENSIONS:

WALL: 2-1/2"
 BOTTOM: 2-1/2"
 COVER: 4"
 MANHOLE: 24" I.D. PRECAST CONCRETE RISER
 HEIGHT: 57" O.D.
 LENGTH: 102" O.D.
 WIDTH: 67" O.D.
 BELOW INLET: 46-1/2" O.D.
 LIQUID LEVEL: 42"
 WEIGHT: 6,609 LBS.

INLET AND OUTLET:
 4" CAST-A-SEAL BOOT OR EQUAL

INLET AND OUTLET BAFFLES:
 AS SHOWN

LIQUID CAPACITY: 21.00 GAL/IN

LOADING DESIGN: 8' 0" UNSATURATED SOIL

TANK CAN BE USED AS:
 GREASE INTERCEPTOR

COVER: MIX DESIGN #8 (NO FIBER)
TANK: MIX DESIGN #10 (STRUCTURAL FIBER)

CUSTOMIZED TANKS:
 FOR CUSTOM TANKS CONTACT WIESER CONCRETE

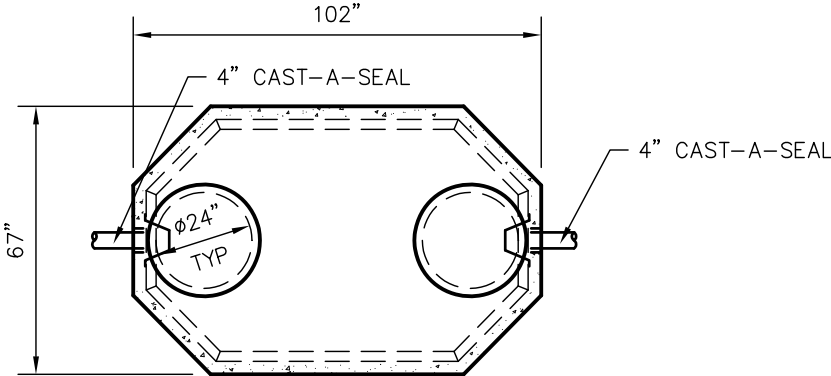

TOP VIEW

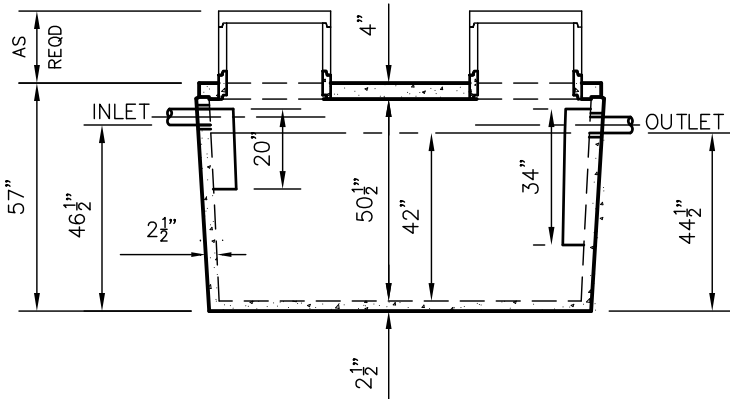

SIDE VIEW

TANKS ARE MANUFACTURED TO MEET OR EXCEED ASTM C-1227 REQUIREMENTS

DRAWINGS SUBMITTED FOR APPROVAL	
APPROVED BY: _____	
APPROVAL DATE: _____	
PRODUCTS NEEDED BY: _____	

W850GI-P	SEPTIC MANUAL	PRE-POUR:	SCALE: 1/4"=1'-0"	POST-POUR:
		DRAWN BY: WCP	REV. DATE:	
		DATE: 00/00/00		
WIESER CONCRETE W3716 US HWY 10 MAIDEN ROCK, WI 54750 800-325-8456				FILE: W850GI-P
		SHEET NO. 1 OF 1		