

# W840/500-MR TANK SPECIFICATIONS

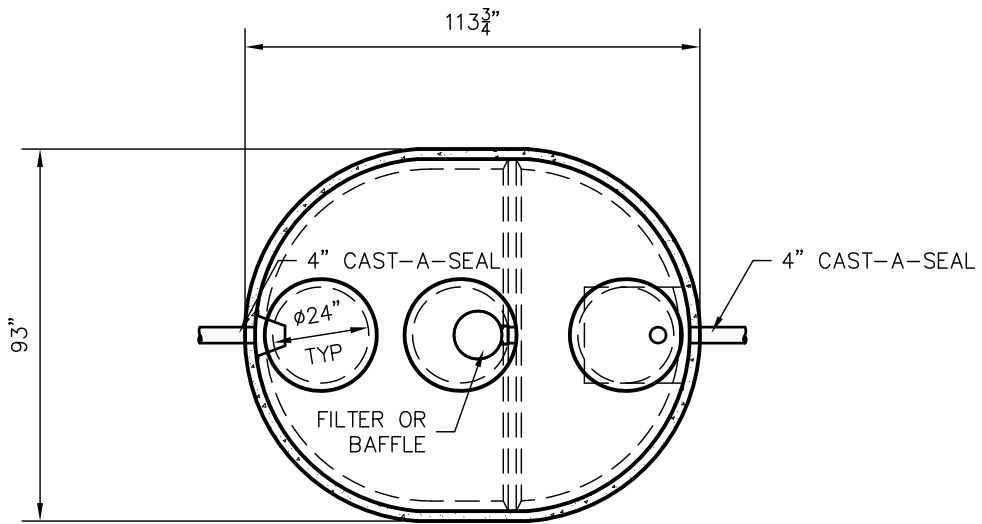

TOP VIEW

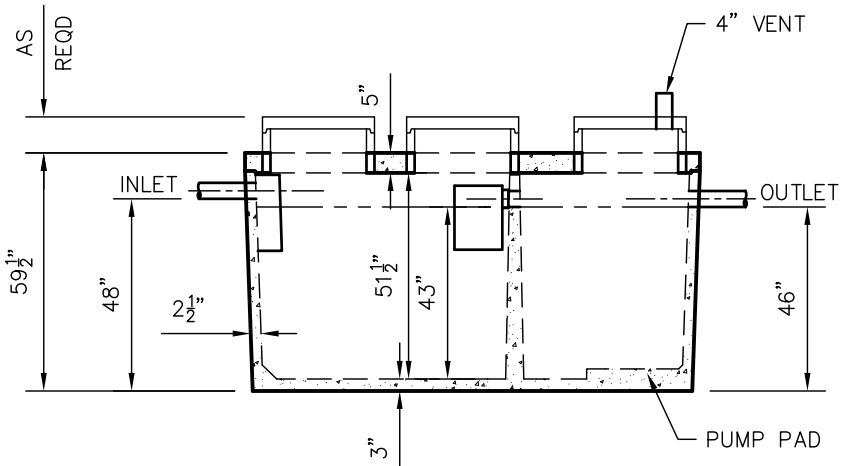

SIDE VIEW

**DIMENSIONS:**  
 WALL: 2 1/2"  
 BOTTOM: 3"  
 COVER: 5"  
 MANHOLE: 24" I.D. PRECAST CONCRETE RISER  
 HEIGHT: 59 1/2" O.D.  
 LENGTH: 113 3/4" O.D.  
 WIDTH: 93" O.D.  
 BELOW INLET: 48" O.D.  
 LIQUID LEVEL: 43"  
 WEIGHT: 11,150 LBS.

**INLET AND OUTLET:**  
 4" CAST-A-SEAL BOOT OR EQUAL  
 GASKET, CAST-A-SEAL BOOT OR EQUAL

**INLET AND OUTLET BAFFLE AND FILTER:**  
 WISCONSIN, SEE DETAIL #10  
 (OTHER STATES SEE CHART)

**LIQUID CAPACITY:** 19.61 GAL/IN (SEPTIC)  
 11.82 GAL/IN (PUMP)

**LOADING DESIGN:** 8' 0" UNSATURATED SOIL

**TANK CAN BE USED AS:**  
 SEPTIC/SEPTIC, SEPTIC/PUMP  
 OR SEPTIC/SIPHON

**COVER:** MIX DESIGN #8 (NO FIBER)  
**TANK:** MIX DESIGN #10 (STRUCTURAL FIBER)

**CUSTOMIZED TANKS:**  
 FOR CUSTOM TANKS CONTACT WIESER CONCRETE

DRAWN BY: WCP	SCALE: 1/4"=1'-0"	PRE-POUR:	POST-POUR:
DATE: 00/00/00	REV. DATE:		
FILE: W1000/500-MR			

**WIESER CONCRETE**  
 W3716 US HWY 10 MAIDEN ROCK, WI 54750  
 800-325-8456

W840/500-MR  
 SEPTIC MANUAL

**DRAWINGS SUBMITTED  
 FOR APPROVAL**

APPROVED BY: \_\_\_\_\_  
 APPROVAL DATE: \_\_\_\_\_  
 PRODUCTS NEEDED BY: \_\_\_\_\_

SHEET NO.  
 1 OF 1