

W3000-FDL GREASE INTERCEPTOR TANK SPECIFICATIONS

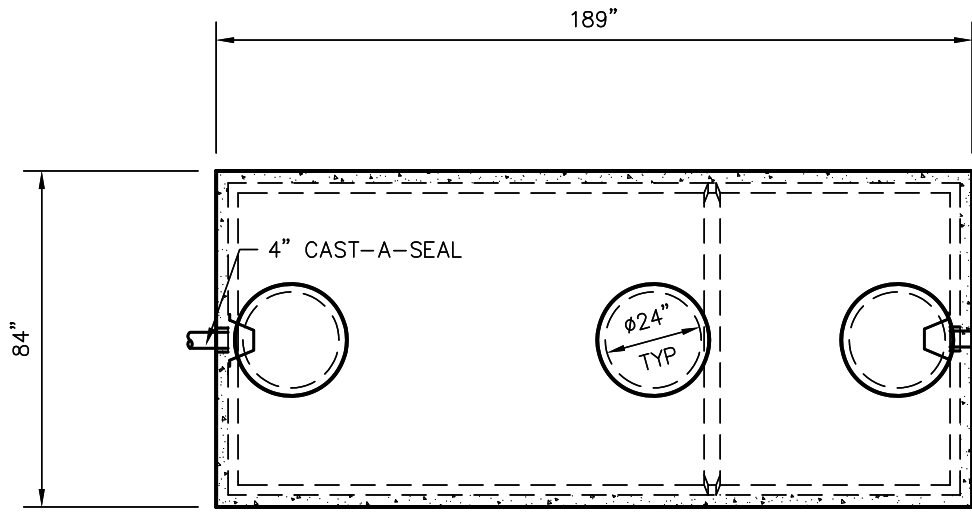

TOP VIEW

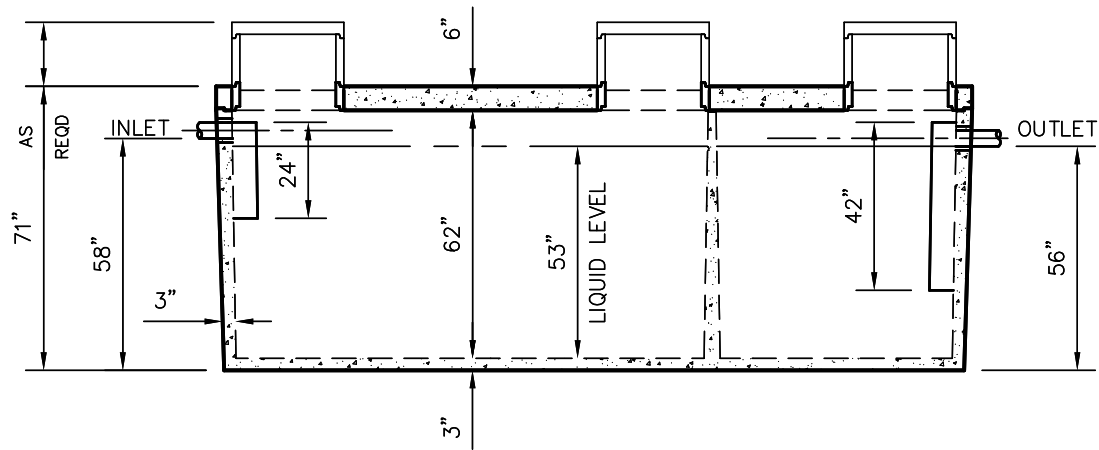

SIDE VIEW

DIMENSIONS:

- WALL: 3"
- BOTTOM: 3"
- COVER: 6"
- MANHOLE: 24" I.D. PRECAST CONCRETE RISER
- HEIGHT: 71" O.D.
- LENGTH: 189" O.D.
- WIDTH: 84" O.D.
- BELOW INLET: 58" O.D.
- LIQUID LEVEL: 53"
- WEIGHT: 23,360 LBS.

INLET AND OUTLET:
4" CAST-A-SEAL BOOT OR EQUAL

INLET AND OUTLET BAFFLES:
AS SHOWN

LIQUID CAPACITY: 57.11 GAL/IN
LOADING DESIGN: 8' 0" UNSATURATED SOIL

TANK CAN BE USED AS:
GREASE INTERCEPTOR

COVER: MIX DESIGN #8 (NO FIBER)
TANK: MIX DESIGN #9 (SMALL FIBER)

CUSTOMIZED TANKS:
FOR CUSTOM TANKS CONTACT WIESER CONCRETE

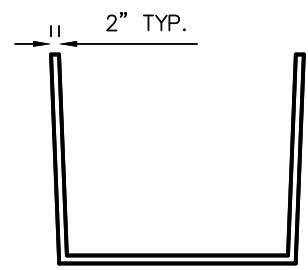

CENTER WALL DETAIL

**DRAWINGS SUBMITTED
FOR APPROVAL**

APPROVED BY: _____

APPROVAL DATE: _____

PRODUCTS NEEDED BY: _____

TANKS ARE MANUFACTURED TO MEET OR EXCEED ASTM C-1227 REQUIREMENTS

DRAWN BY: WCP	SCALE: 1/4"=1'-0"	PRE-POUR:	POST-POUR:
DATE: 00/00/00	REV. DATE:		
<p style="font-size: 24pt; font-weight: bold; margin: 0;">WIESER CONCRETE</p> <p style="font-size: 10pt; margin: 0;">W3716 US HWY 10 MAIDEN ROCK, WI 54750</p> <p style="font-size: 12pt; margin: 0;">800-325-8456</p>			
W3000GI-FDL	SEPTIC MANUAL		
			SHEET NO.
			1 OF 1