

W3000/3000 TANK SPECIFICATIONS

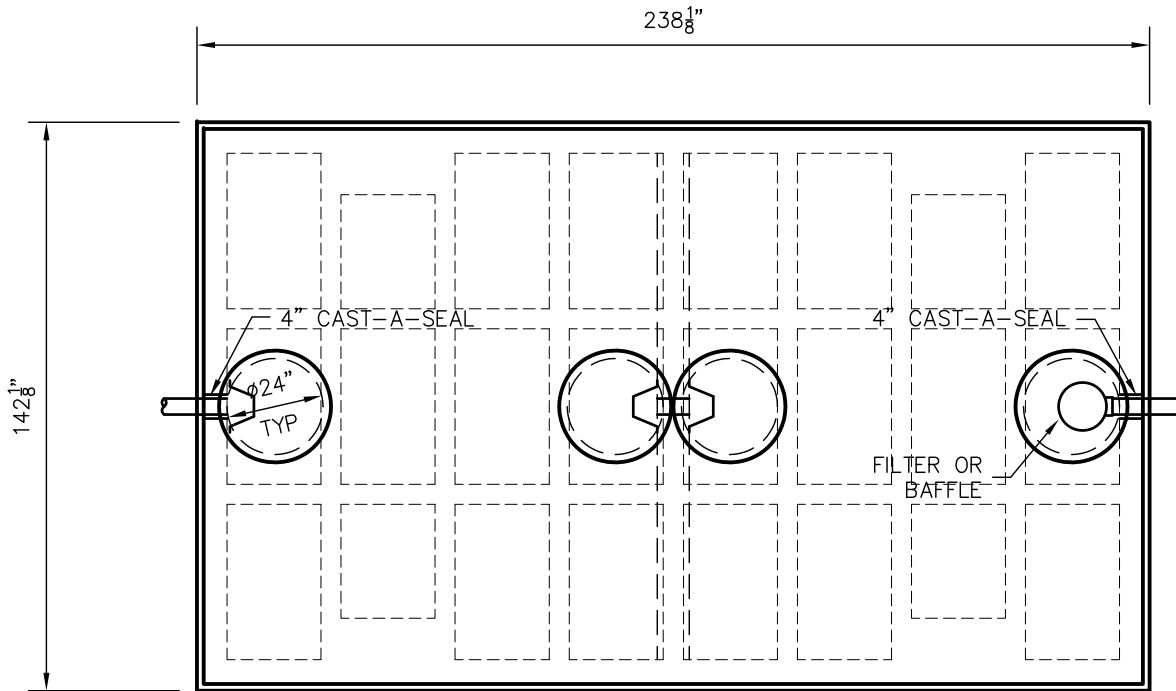

TOP VIEW

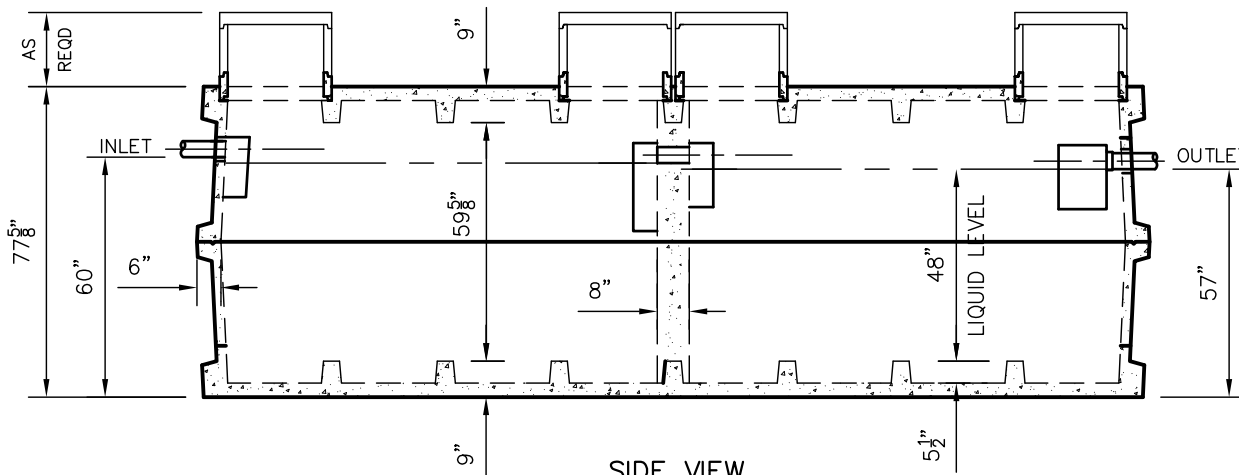

SIDE VIEW

DIMENSIONS:

WALL: 6" RIBBED
 BOTTOM: 9" RIBBED
 COVER: 9" RIBBED
 MANHOLE: 24" I.D. PRECAST CONCRETE RISER
 HEIGHT: 77-5/8" O.D.
 LENGTH: 238-1/8" O.D.
 WIDTH: 142-1/8" O.D.
 BELOW INLET: 60" O.D.
 LIQUID LEVEL: 48"
 WEIGHT: 26,200 LBS PER SECTION

INLET AND OUTLET:

4" CAST-A-SEAL BOOT OR EQUAL

INLET AND OUTLET Baffle and Filter:
 MINNESOTA AS SHOWN

LIQUID CAPACITY: 62.43 GAL/IN (SEPTIC)
 62.43 GAL/IN (PUMP)

LOADING DESIGN: 8'-0" UNSATURATED SOIL

TANK CAN BE USED AS:

SEPTIC/SEPTIC, SEPTIC/PUMP
 OR SEPTIC/SIPHON

TANK: MIX DESIGN #9 (SMALL FIBER)

CUSTOMIZED TANKS:

FOR CUSTOM TANKS CONTACT
 WIESER CONCRETE

TANKS ARE MANUFACTURED TO MEET OR EXCEED ASTM C-1227 REQUIREMENTS

**DRAWINGS SUBMITTED
FOR APPROVAL**

APPROVED BY: _____

APPROVAL DATE: _____

PRODUCTS NEEDED BY: _____

DRAWN BY: WCP	SCALE: 1/4"=1'-0"	PRE-POUR:	POST-POUR:
DATE: 00/00/00	REV. DATE:		
WIESER CONCRETE W3716 US HWY 10 MAIDEN ROCK, WI 54750 800-325-8456			
W3000/3000	SEPTIC MANUAL		
			SHEET NO.
			1 OF 1