

W2000-MR TANK SPECIFICATIONS

DIMENSIONS:

WALL: 2 1/2"
 BOTTOM: SEPTIC 3"
 HEAVY DUTY 5" (ADD 2,050 LBS.)
 COVER: 6"
 MANHOLE: 24" I.D. PRECAST CONCRETE RISER
 HEIGHT: 66" O.D.
 LENGTH: 151" O.D.
 WIDTH: 86" O.D.
 BELOW INLET: 53" O.D.
 LIQUID LEVEL: 46"
 WEIGHT: 13,540 LBS. SEPTIC
 15,370 LBS. HOLDING

INLET AND OUTLET:

4" CAST-A-SEAL BOOT OR EQUAL
 GASKET, CAST-A-SEAL BOOT OR EQUAL

INLET AND OUTLET BAFFLE AND FILTER:

WISCONSIN, SEE DETAIL #10
 (OTHER STATES SEE CHART)

LIQUID CAPACITY: 42.92 GAL/IN

LOADING DESIGN: 8' 0" UNSATURATED SOIL

HOLDING TANK:

OUTLET HOLE PLUGGED
 ACTUAL CAPACITY: 2,146 GALLONS

TANK CAN BE USED AS:

SEPTIC/ HOLDING/ PUMP OR SIPHON

COVER: MIX DESIGN #8 (NO FIBER)

TANK: MIX DESIGN #10 (STRUCTURAL FIBER)

CUSTOMIZED TANKS:

FOR CUSTOM TANKS CONTACT WIESER CONCRETE

**DRAWINGS SUBMITTED
FOR APPROVAL**

APPROVED BY: _____
 APPROVAL DATE: _____
 PRODUCTS NEEDED BY: _____

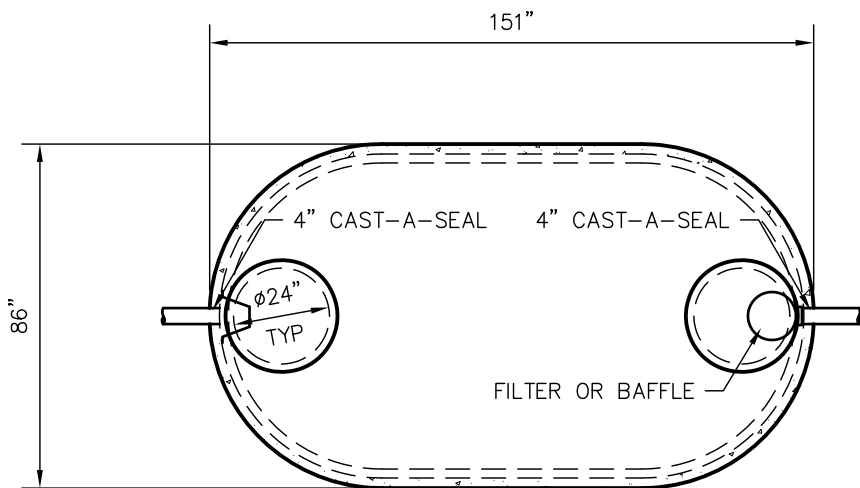

TOP VIEW

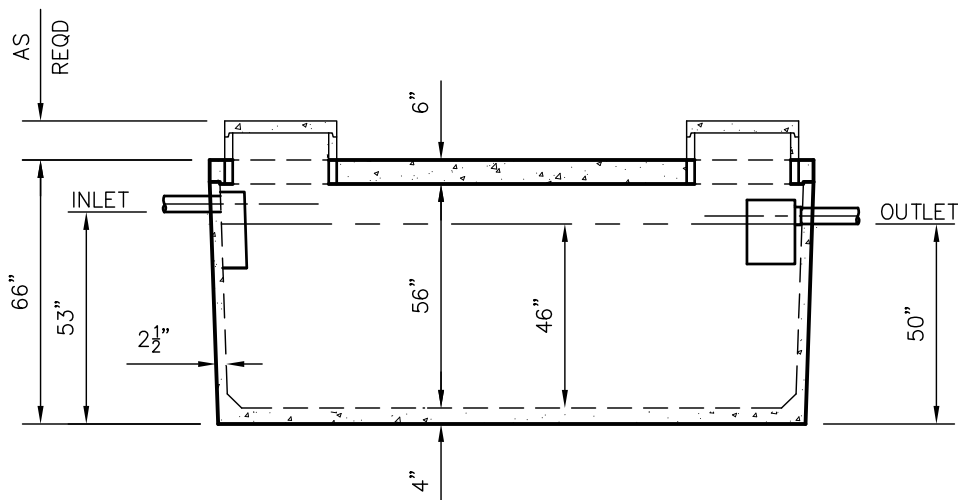

SIDE VIEW

TANKS ARE MANUFACTURED TO MEET OR EXCEED ASTM C-1227 REQUIREMENTS

PRE-FOUR:

SCALE: 1/4"=1'-0"

DRAWN BY: WCP

DATE: 00/00/00

REV. DATE:

FILE: W2000-MR

POST-POUR:

WIESER CONCRETE
 W3716 US HWY 10 MAIDEN ROCK, WI 54750
 800-325-8456

W2000-MR
SEPTIC MANUAL

SHEET NO.
 1 OF 1