

W1565-MR GREASE INTERCEPTOR TANK SPECIFICATIONS

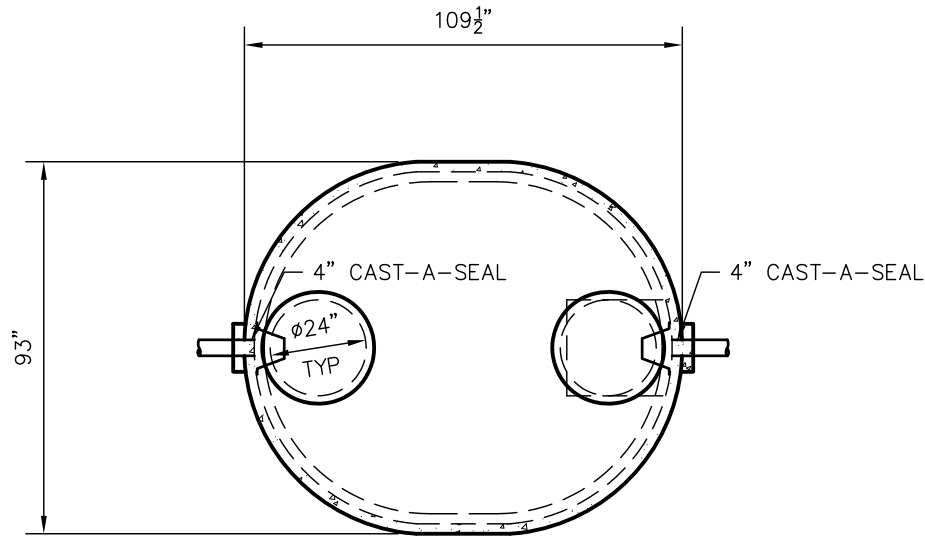

TOP VIEW

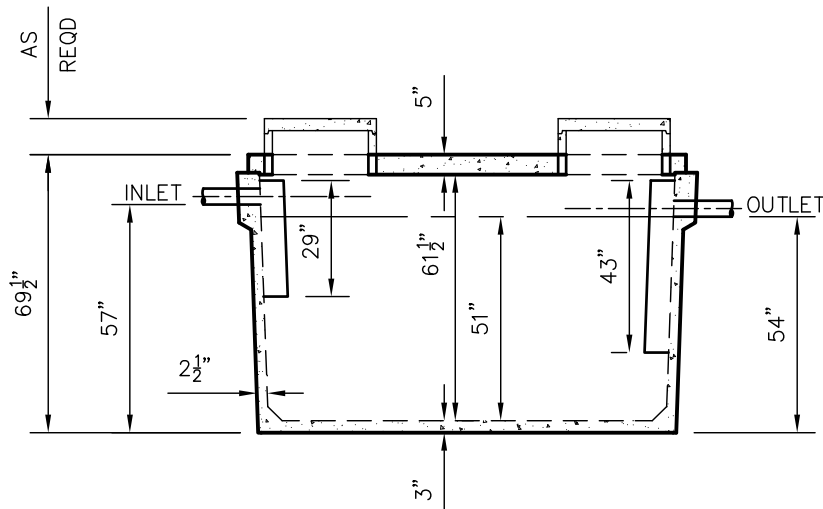

SIDE VIEW

DIMENSIONS:

WALL: 2 1/2"

BOTTOM: 3"

COVER: 5"

MANHOLE: 24" I.D. PRECAST CONCRETE RISER

HEIGHT: 69 1/2" O.D.

LENGTH: 109 1/2" O.D.

WIDTH: 93" O.D.

BELOW INLET: 57" O.D.

LIQUID LEVEL: 51"

WEIGHT: 10,840 LBS.

INLET AND OUTLET:

4" CAST-A-SEAL BOOT OR EQUAL
GASKET, CAST-A-SEAL BOOT OR EQUAL

INLET AND OUTLET BAFFLE:

AS SHOWN

LIQUID CAPACITY: 30.69 GAL/IN

LOADING DESIGN: 8' 0" UNSATURATED SOIL

TANK CAN BE USED AS:

GREASE INTERCEPTOR

COVER: MIX DESIGN #8 (NO FIBER)

TANK: MIX DESIGN #10 (STRUCTURAL FIBER)

CUSTOMIZED TANKS:

FOR CUSTOM TANKS CONTACT WIESER CONCRETE

TANKS ARE MANUFACTURED TO MEET OR EXCEED ASTM C-1227 REQUIREMENTS

**DRAWINGS SUBMITTED
FOR APPROVAL**

APPROVED BY: _____

APPROVAL DATE: _____

PRODUCTS NEEDED BY: _____

SCALE: 1/4"=1'-0"	PRE-POUR:
REV. DATE:	POST-POUR:
DRAWN BY: WCP	
DATE: 00/00/00	
FILE: W1565G-MR	

WIESER CONCRETE
W3716 US HWY 10 MAIDEN ROCK, WI 54750
800-325-8456

W1565GI-MR
SEPTIC MANUAL

SHEET NO.
1 OF 1