

W1000-P GREASE INTERCEPTOR TANK SPECIFICATIONS

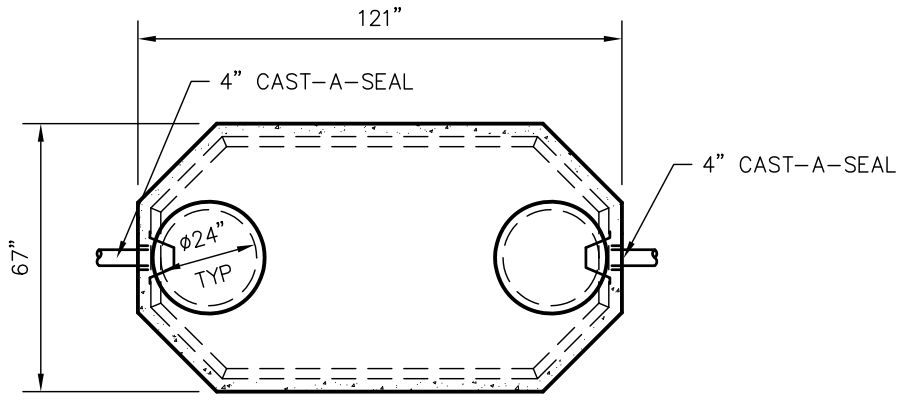

TOP VIEW

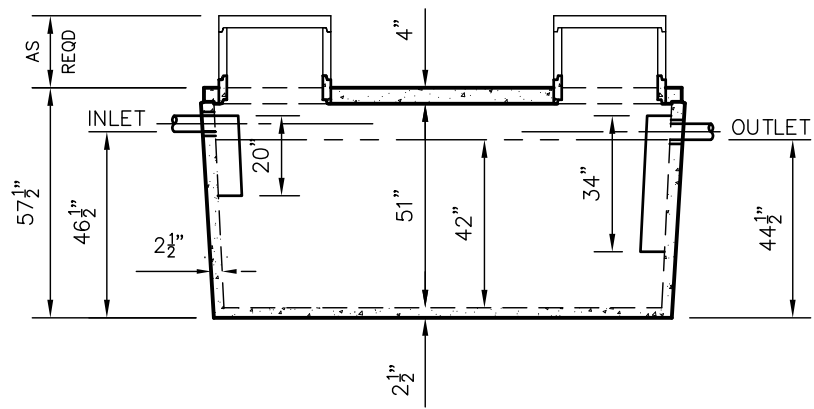

SIDE VIEW

DIMENSIONS:
 WALL: 2-1/2"
 BOTTOM: 2-1/2"
 COVER: 4"
 MANHOLE: 24" I.D. PRECAST CONCRETE RISER
 HEIGHT: 57-1/2" O.D.
 LENGTH: 121" O.D.
 WIDTH: 67" O.D.
 BELOW INLET: 46-1/2" O.D.
 LIQUID LEVEL: 42"
 WEIGHT: 8,300 LBS.

INLET AND OUTLET:
 4" CAST-A-SEAL BOOT OR EQUAL

INLET AND OUTLET BAFFLES:
 AS SHOWN

LIQUID CAPACITY: 26.00 GAL/IN

LOADING DESIGN: 8' 0" UNSATURATED SOIL

TANK CAN BE USED AS:
 GREASE INTERCEPTOR

COVER: MIX DESIGN #8 (NO FIBER)
TANK: MIX DESIGN #10 (STRUCTURAL FIBER)

CUSTOMIZED TANKS:
 FOR CUSTOM TANKS CONTACT WIESER CONCRETE

TANKS ARE MANUFACTURED TO MEET OR EXCEED ASTM C-1227 REQUIREMENTS

**DRAWINGS SUBMITTED
FOR APPROVAL**

APPROVED BY: _____

APPROVAL DATE: _____

PRODUCTS NEEDED BY: _____

PRE-POUR:		SCALE: 1/4" = 1'-0"	
DRAWN BY: WCP	DATE: 00/00/00	REV. DATE:	POST-POUR:
WIESER CONCRETE		W3716 US HWY 10 MAIDEN ROCK, WI 54750	
W1000GI-P		800-325-8456	
SEPTIC MANUAL		SHEET NO.	
1		OF 1	