

ADVANTEK AX 20 900 GPD
W2000/1000-FDL
TANK SPECIFICATIONS

DIMENSIONS:
WALL: 3"
BOTTOM: 3"
COVER: 6"
MANHOLE: 24" I.D. PRECAST CONCRETE RISER
HEIGHT: 71" O.D.
LENGTH: 189" O.D.
WIDTH: 84" O.D.
BELOW INLET: 58" O.D.
LIQUID LEVEL: 53"
WEIGHT: 23,000 LBS.

INLET AND OUTLET:
4" CAST-A-SEAL BOOT OR EQUAL

INLET Baffle AND FILTER:
WISCONSIN, SEE DETAIL #10

LIQUID CAPACITY: 37.92 GAL/IN (SEPTIC)
18.98 GAL/IN (PUMP)

LOADING DESIGN: 8' 0" UNSATURATED SOIL

OPTIONAL CONCRETE RISERS AND LIDS

TANK CAN BE USED AS:
ADVANTEK AX 20 900 GPD

COVER: MIX DESIGN #8 (NO FIBER)
TANK: MIX DESIGN #9 (SMALL FIBER)

CUSTOMIZED TANKS:
FOR CUSTOM TANKS CONTACT WIESER CONCRETE

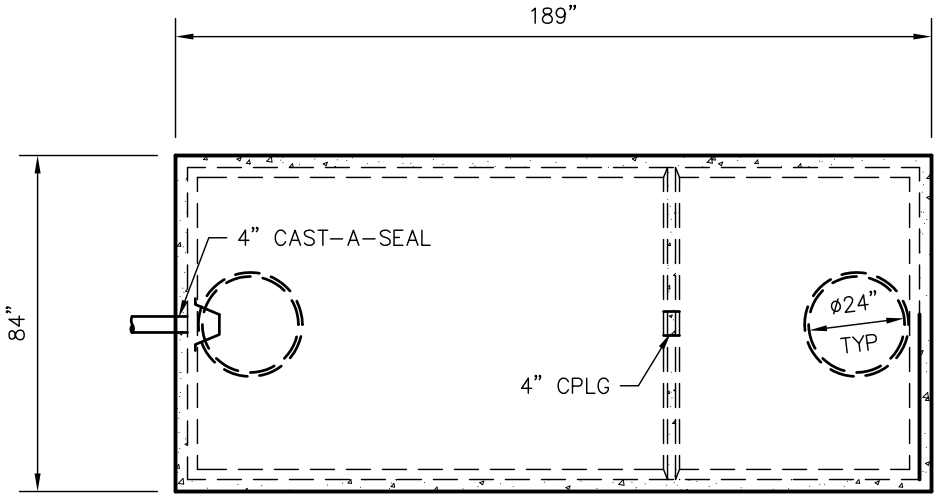

TOP VIEW

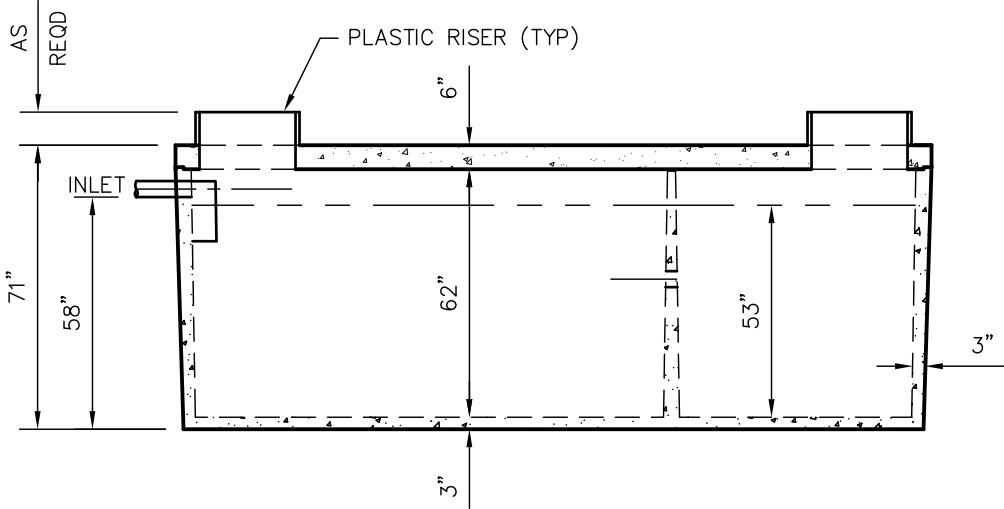

SIDE VIEW

TANKS ARE MANUFACTURED TO MEET OR EXCEED ASTM C-1227 REQUIREMENTS

**DRAWINGS SUBMITTED
FOR APPROVAL**

APPROVED BY: _____
APPROVAL DATE: _____
PRODUCTS NEEDED BY: _____

PRE-POUR:
POST-POUR:

SCALE: 1/4"=1'-0"
REV. DATE:

DRAWN BY: WCP
DATE: 00/00/00

WIESER CONCRETE
W3716 US HWY 10 MAIDEN ROCK, WI 54750
800-325-8456

ADVANTEK AX20 900 GPD
W2000/1000-FDL
SEPTIC MANUAL

SHEET NO.
1 OF 1

FILE: ADVANTEK W2000/1000-FDL